



CITY OF MARYSVILLE

PUBLIC WORK DEPARTMENT

YUBA COUNTY CALIFORNIA

REQUEST FOR QUALIFICATION & PROPOSALS

for

**CITY HALL Window Replacement-Retrofit &
Flashing**

CITY CONTRACT: 00-00

These Specifications were prepared by or
under the direction and responsible
charge.

Jerry Handy, 4JCON LLC Date: 5/14/2026

Sealed proposals will be received and submitted to the City Clerk's office at 526 C Street,
Marysville, CA 95901 until **June 25th, 2026 2:00PM LOCAL TIME**

**CITY OF MARYSVILLE
CONTRACT DOCUMENTS**

TABLE OF CONTENTS

PART 1 BIDDING REQUIREMENTS	I
CITY OF MARYSVILLE - REQUEST FOR QUALIFICATION AND PROPOSAL (RFQP) .	1-1
INSTRUCTIONS TO BIDDERS.....	1-6
BIDDER'S CHECKLIST	1-15
BID PROPOSAL	1-17
BID SECURITY.....	1-18
NON-COLLUSION DECLARATION	1-19
EXPERIENCE & QUALIFICATIONS	1-20
DESIGNATION OF SUBCONTRACTORS.....	1-21
PART 2 CONTRACT DOCUMENTS	I
CONSTRUCTION CONTRACT.....	2-1
PERFORMANCE BOND.....	2-4
PAYMENT BOND	2-6
CONTRACTOR'S CERTIFICATE REGARDING WORKER'S COMPENSATION.....	2-8
PART 3 GENERAL CONDITIONS	33
SECTION 1 DEFINITIONS AND TERMS.....	3-1
SECTION 2 SCOPE OF WORK.....	3-6
SECTION 3 CONTROL OF WORK.....	3-16
SECTION 4 CONTROL OF MATERIALS.....	3-27
SECTION 5 LEGAL RELATIONS AND RESPONSIBILITY	3-30
SECTION 6 PROGRESS AND COMPLETION OF WORK	3-45
SECTION 7 MEASUREMENT AND PAYMENT	3-53
PART 4 SUPPLEMENTAL CONDITIONS (SPECIAL PROVISIONS)	I
SUPPLEMENTAL CONDITIONS (SPECIAL PROVISIONS).....	4-1
PART 5 TECHNICAL SPECIFICATIONS	5-1

Attachments:

- Attachment 1 - General Overview, Description of Windows & Flashing and Specifications.

PART 1 BIDDING REQUIREMENTS

CITY OF MARYSVILLE - REQUEST FOR QUALIFICATION AND PROPOSAL (RFQP)

The following request for qualification and proposal involves labor and materials for the construction of :

CITY HALL WINDOW REPLACEMENT – RETROFIT & FLASHING

Sealed proposals will be received and submitted to the City Clerk’s office at 526 C Street, Marysville, CA **until 2:00 PM local time on June 25th, 2026**, at which time and place they will be read out loud.

TENTATIVE CITY SCHEDULE:

Bid Publication			May 15th, 2026
Cutoff for Pre-Bid RFIs / Equal materials	no later than	5:00 P.M.	June 18th, 2026
Bids Due / Bid Opening	no later than	2:00 P.M.	June 25th, 2026
Award of Contract			July 21st, 2026

Mandatory Pre-Bid Site Meeting: June 10th, 2026 10:30 AM (Windows) & 1:30 PM (Restrooms)

Marysville City Hall – 526 C Street, Marysville, Ca. 95901

Project construction cost estimate:

1. **Completion of Work:** All work shall be completed within (60) working days from the date designated on the Notice to Proceed.

2. **Obtaining Contract Documents:** Contract documents including the complete Request for Qualification and Proposal **are available for downloading free of charge through the City’s Website system (insert link here)**. The bidder must contact the City to be placed on the bidders list.

3. **Amendment and Cancellation:** The City reserves the right to amend, cancel, or reissue this bid at any time and at its sole discretion. Any amendment shall be in writing and posted to the City’s website. A potential Bidder is solely responsible for either contacting the City to receive or checking the City website for notifications and shall be solely responsible for complying with such notifications.

4. **Questions:** Project-specific questions and RFI’s must be submitted via email to jerry@4jcon.com . All contractor or equal materials shall be submitted with the questions. The City will post responses to Bidder questions on the City website and email to the bidders on the bidders list. The cutoff date for submittal of questions is **June 18th, 2026** by 5:00 pm local time.

5. **Project Scope:**

WINDOWS - Remove and Replace existing windows at City Hall and the Police Department with retrofit window units. Existing exterior frames shall remain in place. Contractor shall protect surrounding wall finishes during installation.

New Retrofit windows shall be Milgard Tuscany Series V400, or City-approved equivalent, meeting the minimum specifications for glass, energy performance, and finishes as indicated in the Technical Specifications.

The work includes field verification of all dimensions and quantities, coordination with the City representative to Schedule installation around City and Police Department operations, and proper installation of safety glazing where required by code.

Contractor Shall provide two special roof access windows located on the north and south sides requiring casement units with full 90-degree swing as indicated in the drawings.

Submission of Proposals: All proposals must be submitted not later than the date and time prescribed. The Bidder is wholly responsible to ensure its Bid is submitted on the date and at the time and place designated for the opening of bids. Any Bid received after the time and date specified shall not be considered. Any Bid may be withdrawn prior to the scheduled time for opening bids.

Each Bid must conform and be responsive to this notice and consistent with the Contract Documents.

6. **Bid Security:** Each proposal must be accompanied by a Bid Security in the form of a cashier's check, certified check, or Bid bond executed on the prescribed form, in an amount not less than ten percent (10%) of the total Bid price payable to the City of Marysville.

Bidders are hereby notified that in accordance with the provisions of Public Contract Code section 22300, securities may be substituted for any monies which the City may withhold pursuant to the terms of this Contract to ensure performance.

7. **Construction License:** The Bidder Shall Possess a current C-17 Glazing Contractor license issued by the State of California at the time the Bid is submitted and shall maintain such license throughout the duration of the project. The City reserves the right to request documentation verifying licenses.

8. **Installer Qualifications:** Installer shall be a contractor licensed in the State of California holding a C-17 Glazing Contractor License. Installer shall meet one of the following qualifications:

- A. Contractor is an authorized dealer of the specified manufacturer or
- B. Installation Supervisor or lead installer holds FGIA/AAMA Installation Masters Certification or equivalent manufacturer-approved installation training.

9. **Contractor Registration:** All Bidders, and Subcontractors subject to Public Contract Code section 4104, must have registered with the California State Department of Industrial Relations pursuant to Labor Code section 1725.5 prior to submitting a bid. Furthermore, a Contractor, and all Subcontractors subject to Public Contract Code section 4104, must be registered pursuant to Labor Code section 1725.5 before entering into a contract to work on a public project.

10. **Wage Rates:** Bidders are hereby notified that the California Department of Industrial Relations has determined the general prevailing rate of wages for each craft, classification, or type of worker needed to execute the work. Copies of the current schedules for prevailing wages are on file in the City's office, and the contents of those schedules are included herein as if set forth in full.

11. **Prohibition of Respondent Terms and Conditions:** A Bidder shall not submit their own contract terms and conditions in a Proposal. If a Proposal contains such terms and conditions, the City, at its sole discretion, may reject the Proposal. A Bidder may either submit Questions to gain clarification on a term of the City's standard contract or submit proposed revisions to the City's standard contract in redline as part of the Proposal Transmission Letter, both pursuant to the terms of this RFQP.

12. **Joint Ventures and Partnering:** A Proposal from joint ventures or entities partnering for a specific service must be designed to minimize any administrative burden on the City as a result of the participation of multiple entities. Joint proposals must adhere to the following:

- A. The Proposal shall respond to each section and subsection of this RFQP.
- B. The Proposal shall clearly set forth the respective responsibilities and functions that each Principal of the joint venture or partnering entities would perform if awarded a Contract pursuant to this RFQP.
- C. The Proposal must include a copy of the joint venture or partnering agreement(s) that identify the Principals involved, as well as their rights and responsibilities regarding the Contract pursuant to this RFQP.
- D. The Proposal Transmittal Letter must be signed by each Principal of the joint venture and include all required information.

13. **Proposal of Alternate Services:** A Proposal for alternate services (i.e., proposals that offer something different from that requested by the RFQP), will be considered nonresponsive and rejected.

14. **Proposal of Additional Services:** A Proposal may indicate and offer services in addition to those required by this RFQP. These additional services may be added to the Contract, at the sole discretion of the City. The cost for any such additional services shall be mutually agreed upon by the Contractor and the City, and incorporated into the Contract before execution, but not used for basis of award of the contract.

15. **Severability:** If any provision of this RFQP is declared by a court to be illegal or in conflict with any law, the validity of the remaining terms and provisions shall not be affected, and the rights and obligations of the City and Bidders shall be construed and enforced as if the RFQP did not contain the particular provision held to be invalid.

16. **Disclosure of Proposal Contents:** All Proposals and other materials submitted to the City related to this RFQP shall become the property of the City. Selection or rejection of a Proposal does not affect this right. All proposal information, including detailed price and cost information, shall be held in confidence during the evaluation and selection process. Upon the completion of the evaluation and selection process, or by rejection of all Proposals, the Proposals and shall be open for review by the public to the extent required by the California Public Records Act, Government Code section 6254 et seq.. By submitting a Proposal, a Bidder acknowledges and accepts that the contents of the Proposal and associated documents shall become open to public inspection.

Portions of a Proposal exempt from public disclosure by law may be protected from public disclosure by the City. A Bidder is required to clearly label such portion of a Proposal

"CONFIDENTIAL" and list the grounds for non-disclosure. In doing so, the Bidder thereby agrees to indemnify and defend the City from any action arising from the non-disclosure of the information. The failure to so label any information shall constitute a complete waiver of all claims for damages caused by or related to any release of the information.

17. Conflict of Interest and Restrictions: By submitting a Proposal, the Bidder certifies that no amount shall be paid directly or indirectly to an employee or official of the City as wages, compensation, or gifts in exchange for acting as an officer, agent, employee, subcontractor, or consultant to the Bidder in connection with the procurement under this RFQP.

18. Proprietary Information: A copy of each Proposal shall be retained for official files and will become public record after the award of a contract unless the Proposal, or specific parts of the Proposal, can be shown to be exempt by law. Each Bidder may clearly label any part of a Proposal as "CONFIDENTIAL." In doing so, the Bidder thereby agrees to indemnify and defend the City for withholding the information from public inspection. Failure to label information shall constitute a complete waiver of all claims for damages caused by or related to any release of the information.

If a public records request for appropriately-labeled information is received by the City, the City will endeavor to notify the Bidder of the request and delay access to the material until seven (7) working days after the City's notice. Within that time delay, it will be the duty of the Bidder to act in protection of its labeled information. Failure to so act shall constitute a complete waiver.

19. Rejection of Bids: The City reserves the right, at its sole discretion, to reject any and all Proposals, no matter their level of responsiveness, or to cancel this RFQP in its entirety. A Bidder must comply with all of the terms and instruction of this RFQP, and all applicable state and local laws and regulations. Any Bidder that does not meet the requirements or qualifications of this RFQP may be considered to be nonresponsive or not responsible and rejected. A Bidder may not restrict the rights of the City or otherwise qualify a Proposal. If a Bidder does so, the City may determine the Proposal is a nonresponsive counteroffer, and the Proposal may be rejected. The City reserves the right, at its sole discretion, to waive variances in a Proposal, provided such action is in the best interest of the City. Where the City waives variances in a Proposal, such waiver does not modify the RFQP requirements or excuse the Bidder from full compliance with the RFQP. Notwithstanding any variance, the City may hold any Bidder to strict compliance with the RFQP.

20. Disqualification of Bidder: If there is a reason to believe that collusion exists among any Bidders, none of the bids of the participants in such collusion will be considered and the City may likewise elect to reject all bids received.

21. Relief of Bidder: Attention is directed to the provisions of Public Contracts Code section 5101 and the following, concerning relief of Bidders and in particular to the requirements therein that if the Bidder claims a mistake was made in its bid, the Bidder shall give the City written notice, within five (5) days after the opening of bids of the alleged mistake, specifying in the notice, in detail, how the mistake occurred.

It shall be mandatory for the Contractor and any Subcontractor under it to pay not less than the said specified rates to laborers and workmen employed by them in the execution of the Contract.

22. Award: The award shall be made to the lowest responsive and responsible Bidder whose proposal complies with the specified requirements. The award of the Contract will be made by the Marysville City Council, and the Contractor shall execute the Contract within ten (10) days after it has received the Contract from the City. The City reserves the right to waive

any irregularity in the proposals. No Bid may be withdrawn for a period of sixty (60) days after the opening of bids.

23. **Qualifications:** Bidder must demonstrate that Bidder is qualified to perform the Work as described herein, which includes, but is not limited to, prior project/work experience completing a minimum of three (3) projects of similar size and scope within the previous five (5) years, performing as either a Prime Contractor or Subcontractor. See Attachment 1 "Customer Reference Form" to demonstrate this requirement.

24. **Bonds:** The successful Bidder will be required to furnish a payment bond in an amount equal to one hundred percent (100%) of the Contract price, and a faithful performance bond in an amount equal to one hundred percent (100%) of the Contract price.

25. **Preconstruction Conference:** A preconstruction conference will be convened after the Contractor has delivered the necessary bonds, insurance certificates, and signed agreement in proper form as required in the Request for Qualification and Proposal, Bid proposal, and general conditions of these specifications. Prior to any work, the Contractor shall provide the City with a list of key personnel assigned to the project and the telephone numbers where they may be reached at any time. The list shall be made available in sufficient copies and presented at the preconstruction conference.

26. **Noisy Work / Work Hour Restrictions:** The City Hall and Police Department facilities will remain occupied during construction. Normal City business hours are 8:00 am to 5:00 pm, Monday through Friday. Work that generates excessive noises, vibration, or other disruption to normal City operations, including but not limited to window removal, drilling, cutting, demolition, or similar activities, may be restricted during normal business hours at the discretion of the City. The Contractor may be required to perform such disruptive work during evenings or weekend in order to minimize interference with City Operations. The Contract shall coordinate scheduling of work with the City's designated representative at least **48 hours in advance**. No additional compensation will be allowed for work performed outside normal business hours when required to accommodate City operations. The Contractor shall include in its bid all costs associated with performing work outside normal hours if required.

27. **Executive Order N-6-22 – Russia Sanctions:** On March 4, 2022, Governor Gavin Newsom issued Executive Order N-6-22 (the EO) regarding Economic Sanctions against Russia and Russian entities and individuals. "Economic Sanctions" refers to sanctions imposed by the U.S. government in response to Russia's actions in Ukraine, as well as any sanctions imposed under state law. By submitting a bid or proposal, Contractor represents that it is not a target of Economic Sanctions. Should the State determine Contractor is a target of Economic Sanctions or is conducting prohibited transactions with sanctioned individuals or entities, that shall be grounds for rejection of the Contractor's bid/proposal any time prior to contract execution, or, if determined after contract execution, shall be grounds for termination by the State.

By: _____
Jerry Handy, Construction Manager

Date: 5/14/2026

INSTRUCTIONS TO BIDDERS

1. Introduction

Each Bid shall be in accordance with the Contract Documents.

2. Plans

The plans for the project are provided by Dennis Nelson dated 4-22-25 and revision 10-7-25

3. Local Conditions

(a) The Bidder shall examine carefully the site of the work contemplated and the Contract Documents. The submission of a proposal shall be conclusive evidence that the Bidder has investigated and is satisfied as to the conditions to be encountered, as to the character, quality and quantities of work to be performed and the materials to be furnished, and as to the requirements of the Contract Documents.

(b) Where the City Construction Manager has made investigations of surface and subsurface conditions in areas where work is to be performed under the Contract, or in other areas, some of which may constitute possible local material sources, such investigations were made only for the purpose of study and design. Where such investigations have been made, bidders or Contractor may, upon written request, inspect the records of the City Construction Manager as to such investigations subject to and upon the conditions hereinafter set forth. Such inspection of records may be made at the office of the City Construction Manager.

(c) The records of such investigations are not a part of the Contract and are made available for inspection solely for the convenience of the Bidder or Contractor. It is expressly understood and agreed by Bidder or Contractor that neither the City nor the City Construction Manager assumes any responsibility whatsoever with respect to the sufficiency or accuracy of the investigations thus made, the records thereof, or of the interpretation set forth therein or made by the City Construction Manager in his use thereof and there is no representation, warranty or guarantee, either express or implied, that the conditions indicated by such investigations or records thereof are correct or representative of those existing throughout such areas or any part thereof, or that unanticipated developments may not occur or that materials other than, or in proportions different from, those indicated may not be encountered.

(d) The availability or use of information described in this section or the special conditions is not to be construed in any way as a waiver of the provisions of this section and a Bidder or Contractor is cautioned to make such an investigation and examination as it deems necessary to satisfy itself as to conditions to be encountered in the performance of the work and, with respect to possible local material sources, the quality and quantity of material available from such property and the type and extent of processing that may be required in order to produce material conforming to the requirements of the Specifications.

(e) No information derived from such inspection of records of investigations or compilations thereof made by the Construction Manager or the Construction Manager's assistants, will in any way relieve the Bidder or Contractor from any risk or from properly fulfilling the terms of the Contract.

(f) Information derived from inspection of topographic maps, or from Plans showing location of utilities and structures will not in any way relieve the Contractor from any risk, or from

properly examining the site and making such additional investigations as it may elect, or from properly fulfilling all the terms of the Contract.

(g) Each Bidder shall inform itself of, and the Bidder awarded a Contract shall comply with, federal, state and local laws, statutes, and ordinances relative to the execution of the work. This requirement includes, but is not limited to, applicable regulations concerning employment of labor, protection of public and employee safety and health, protection, the protection of natural resources, fire protection, burning and non-burning requirements, permits, fees, and similar subjects.

4. Form of Bid and Signature

(a) Bids shall be submitted and enclosed in a sealed envelope and marked and addressed as hereinafter directed. The Bidder shall state in figures the unit prices or the specific sums as the case may be, for which it proposes to supply the labor, materials, supplies or machinery, and perform the work. Bid prices will be deemed to include all applicable fees and taxes including sales tax. If the Bid is made by an individual, it shall be signed by the individual and the individual's full name and address shall be given; if it is made by a partnership, it shall be signed with the co-partnership name by a member of the partnership, who shall also sign the member's own name, and the name and address of each member of such partnership shall be given; and, if it is made by a corporation, the name of the corporation shall be given and it shall be signed by its duly authorized officer or officers attested by the corporate seal, the name and titles of all officers of the corporation shall be given, and the address of the corporation and the state in which incorporated shall be stated.

(b) Bids will be considered only from persons or entities licensed as required under applicable provisions of the Contractor's License Law (Cal. Bus. and Prof. Code section 7000, *et seq.*) and rules and regulations adopted pursuant thereto; and each Bidder shall insert its type of Contractor's license, license number, and other requested information in the place provided in the bid. No oral, telephonic or facsimile Bid or modification of a Bid will be considered.

(c) Effective March 1, 2014, all bidders must have registered with the California State Department of Industrial Relations pursuant to Labor Code section 1725.5 prior to submitting a bid. Furthermore, effective April 1, 2015, a Contractor must be registered pursuant to Labor Code section 1725.5 before entering into a contract to work on a public project.

5. Submittal of Bids

(a) All Bids must be submitted not later than the time prescribed, at the place and in the manner set forth in the Request for Qualification and Proposal. A complete Bid requires submission of all documents identified in subsection (d) below. Each Bid must be submitted in a sealed envelope addressed to City of Marysville, City Clerk, 526 C Street, Marysville, California 95901 and designated as a Bid bearing the name of the Bidder and name of the project. The Bidder is wholly responsible to see that its Bid is submitted at the time and place named for the opening of bids.

(b) Bids shall include all Addenda or clarifications issued during the bidding period acknowledged by the bidder's signature thereon. Failure to so include or acknowledge an addendum or clarification may result in the Bid being rejected as not responsive.

(c) Bids shall be opened at the time and place specified in the Request for Qualification and Proposal, unless changed by addendum.

- (d) Bid documents to be submitted shall include the following:
 - (1) Signed Proposal
 - (2) Bid Security (if a Bid bond, to be accompanied by power of attorney, both executed and notarized)
 - (3) Non-Collusion Declaration
 - (4) Experience & Qualification Form
 - (5) Completed Subcontractor List
 - (6) Bidder's Checklist
 - (7) Attachment 1 - Customer Reference Form
 - (8) Additional Design-Build Proposal for Marysville Police Department

6. Preparation of Bid

Blank spaces in the Bid shall be properly completed. The phraseology of the Bid must not be changed and no additions shall be made to the items mentioned therein. Unauthorized conditions, limitations or provisions attached to a Bid will render it informal and may cause its rejection. If erasures, interlineations or other changes appear on the form, each erasure, interlineation or change must be initialed by the person signing the Bid. Bids received after the time fixed, or received at any place other than the place stated in the Request for Qualification and Proposal may not be considered. All bids will be opened and read publicly. Bidders, their representatives and other interested parties are invited to be present at the opening. Where bonds are required, the Bidder shall name in its Bid the surety or sureties who have agreed to furnish said bonds.

7. Bid Security

(a) All Bids shall be accompanied by a Bid Security. Such Bid Security shall include cash, cashier's or certified check made payable to the City or a Bid Bond executed by an admitted surety insurer. The Bid Security must be enclosed in the same envelope with the Bid. The amount of the Bid Security shall be not less than ten percent (10%) of the total amount of the Bid.

(b) The Attorney-in-Fact (resident agent) who executes the Bid Bond on behalf of the surety company must attach a copy of its Power of Attorney as evidence of its authority. A notary shall acknowledge the power as of the date of execution of the surety bond which it covers.

(c) Bid Bonds must be provided on the Bid Bond form furnished by the City. The Bid Bond must be furnished by a company, acceptable to the City, that is authorized and licensed by the Insurance Commissioner as an "admitted surety insurer" and that maintains at least one office in California for conducting business.

8. List of Subcontractors

(a) Each Bidder shall set forth in its Bid on the form provided the following information in accordance with the provisions of Public Contract Code sections 4100-4113:

(1) The name, Contractor 's license number, public works Contractor registration number and the location of the place of business of each Subcontractor who will perform work or labor or render service to the prime Contractor in or about the construction of the work or improvement, or a Subcontractor licensed by the State of California who, under subcontract to the prime Contractor, specifically fabricates and installs a portion of the work or improvement according to the Contract Documents, in any amount in excess of one-half of one percent (0.5%) of the prime Contractor's total Bid, or ten thousand dollars (\$10,000.00), whichever is greater.

(2) The portion of the work which will be done by each such Subcontractor. Only one Subcontractor shall be listed for each such portion of the work as defined in the Bid.

(3) The Bidder is considered the Prime Contractor and shall perform at least 51 percent (51%) of the work, as determined by a percentage of the value of the work.

(b) If the Bidder fails to specify a Subcontractor for any portion of the work to be performed under the Contract, the Bidder agrees to perform that portion of the work itself.

9. Interpretation of Contract Documents

Any explanation desired by the bidders regarding the meaning or interpretation of any of the Contract Documents must be submitted in writing at least five (5) calendar days prior to the Bid opening. Requests for clarification received after the above noted deadline may be answered at the discretion of the Construction Manager or Project Manager. Any such explanations or interpretations will be made in the form of Addenda to the documents and will be furnished to all bidders who shall submit all Addenda with their Bids. Neither the Construction Manager nor any representative of the City is authorized to give oral explanations or interpretations of Contract Documents, and a submission of a Bid constitutes agreement by the Bidder that it has placed no reliance on any such oral explanation or interpretation. However, the Construction Manager may, upon inquiry by bidder, orally direct the bidder's attention to specific provisions of the Contract Documents which cover the subject of the inquiry. Requests for Clarifications during the Bid period shall be emailed to:

Attn: Jerry Handy
4JCON LLC
Jerry@4jcon.com

10. Modification of Bids

A Bidder may modify its Bid by written communication provided such communication is received by the City prior to the closing time for receipt of Bids. The written communication should not reveal the Bid price but should state the addition or subtraction or other modification so that the final prices or terms will not be known by the City until the sealed Bid is opened.

11. Withdrawals of Bids

Bids may be withdrawn without prejudice by written or facsimile requests received from Bidder prior to the time for opening of Bids, and Bids so withdrawn will be returned to bidders unopened when reached in the process of opening Bids. No Bid may be withdrawn after the hour affixed for opening Bids without rendering the accompanying Bid Security subject to

retention as liquidated damages in like manner as in the case of failure to execute the Contract after award, as in the Contract Documents herein provided. Negligence on the part of the Bidder preparing its Bid shall not constitute a right to withdraw the Bid subsequent to the opening of Proposals.

12. **Discrepancies**

In the case of discrepancy between unit prices and totals, unit prices will prevail and the City will recalculate the Bid total based on the unit prices and estimated quantities. In case of discrepancy between words and figures, words will prevail.

13. **Servicing and Maintenance**

Each Bidder must, if requested, furnish evidence that there is an efficient service organization which regularly carries a stock of repair parts for any proposed equipment to be furnished and installed in the work and that the organization is conveniently located for prompt service.

14. **Disqualification of Bidders**

(a) More than one Bid from an individual, firm, partnership or corporation under the same or different names will not be considered. Reasonable grounds for believing that any individual, firm, partnership or corporation is interested in more than one Bid for the work contemplated may cause the rejection of all Bids in which the individual, firm, partnership or corporation is interested. If there is reason for believing that collusion exists among the bidders, any or all Bids may be rejected. Bids in which the price is obviously unbalanced may be rejected.

(b) All bidders are put on notice that any collusive agreement fixing the prices to be Bid so as to control or affect the awarding of this Contract is in violation of the competitive bidding requirements of the Public Contract Code and may render void any Contract let under such circumstances.

15. **Opening & Award of Contract**

Bids will be opened publicly and read aloud at the time and date established in the Request for Qualification and Proposal. Bid Summaries may be made available to Bidders after the Bid Date.

(a) The City reserves the right to accept or reject any and all Bids for a period of sixty (60) days after the date of opening, and to waive any informality or irregularity in any Bid. No Bid can be withdrawn during that period, except pursuant to Public Contract Code section 5102, *et seq.*

(b) The City reserves the right to reject any or all Bids, including, without limitation, the right to reject any non-conforming, non-responsive, unbalanced, or conditional bids.

(c) Before a Bid is considered for award, the City may, in addition to the Experience & Qualifications form included in the Bid documents, require a Bidder to submit a statement of facts and detail as to its business, technical organization and financial resources and equipment available and to be used in performing the work. The City expressly reserves the right to reject any Bid if it determines that the business and technical organization, equipment, financial and

other resources or other experience of the Bidder (including the bidder's Subcontractors) is not sufficiently qualified for the work Bid upon and, therefore, justifies such rejection.

(d) The award of the Contract, if it is awarded, will be to the lowest responsive responsible Bidder whose Bid complies with the requirements and qualifications set forth herein.

(e) The issuance by the City of a notice to the successful Bidder of the award of the Contract ("Notice of Award") shall be deemed the Award of Contract.

16. Bid Protests

The lack of a prompt procedure to resolve disputes regarding the bidding process would impair the City's ability to carry out its purpose of constructing this project in a timely manner. Therefore, to the maximum extent authorized by law and notwithstanding any other procedures specified in documents referenced herein, all disputes and/or protests regarding the bidding process shall be subject to the following procedure. In submitting a Bid to the City for this project, the Bidder agrees to comply with and to be bound by this procedure:

Any Bid protest must be submitted in writing to the Director of Public Works of the City of Marysville before 5:00 p.m. on the fifth (5th) working day following Bid opening.

(a) The initial protest document must contain a complete statement of the basis for the protest, and all supporting documentation.

(b) The party filing the protest must have actually submitted a Bid for the Work. A Subcontractor of a party submitting a Bid for the Work may not submit a Bid protest. A party may not rely on the Bid protest submitted by another Bidder, but must timely pursue its own protest.

(c) The protest must refer to the specific portion of the Contract Documents which forms the basis for the protest.

(d) The protest must include the name, address and telephone number of the person representing the protesting party.

(e) The party filing the protest must concurrently transmit a copy of the initial protest document and any attached documentation to all other parties with a direct financial interest which may be adversely affected by the outcome of the protest. Such parties shall include all other Bidders who appear to have a reasonable prospect of receiving an award depending upon the outcome of the protest.

(f) The City will give the protested Bidder five (5) working days after the receipt of the protest to submit a written response. The responding Bidder shall transmit the response to the protesting Bidder concurrent with delivery to the City.

(g) The procedure and time limits set forth in this paragraph are mandatory and are the Bidder's sole and exclusive remedy in the event of Bid protest. The Bidder's failure to comply with these procedures shall constitute a waiver of any right to further pursue the Bid protest, including filing a Government Code Claim or legal proceedings.

(h) If the City determines that a protest is frivolous, the protesting Bidder may be determined to be non-responsible and that Bidder may be determined to be ineligible for future contract awards.

17. Contract Bonds

(a) The successful Bidder shall furnish both a Performance Bond and a Payment Bond in the amount of one hundred percent (100%) of its Total Bid Price.

(b) These Bonds shall be furnished in the forms enclosed following the Contract and shall be satisfactory to the City and shall be obtained from a responsible corporate surety (or sureties) acceptable to the City, which is admitted by the State of California to act as surety upon bonds and undertakings and which maintains in this State at least one office for the conduct of its business. The surety (or sureties) shall furnish reports as to its financial condition from time to time as requested by the City. The premiums for said Bonds shall be paid by the successful bidder.

(c) These Bonds shall be furnished by companies who are authorized and licensed by the Insurance Commissioner as an “admitted surety insurer.” The surety shall provide the City with the documentation required by Section 995.660 of the California Code of Civil Procedure.

(d) If any surety becomes unacceptable to the City or fails to furnish reports as to its financial condition as requested by the City, the Contractor shall promptly furnish such additional security as may be required from time to time to protect the interests of the City and of persons supplying labor or materials in the prosecution of the work contemplated by this Contract.

(e) In the event of any conflict between the terms of the Contract and the terms of the Bonds, the terms of the Contract shall control and the Bonds shall be deemed to be amended thereby. Without limiting the foregoing, the City shall be entitled to exercise all rights granted to it by the Contract in the event of default, without control thereof by the surety, provided that the City gives the surety notice of such default at the time or before the exercise of any such right by the City, and, regardless of the terms of said Bonds, the exercise of any such right by the City shall in no manner affect the liability of the surety under said Bonds.

18. Substitution of Securities for Monies Withheld

Bidders are hereby notified that in accordance with the provisions of Public Contract Code section 22300, securities may be substituted for any monies which the City may withhold pursuant to the terms of the Contract to insure performance.

19. Execution of Contract

The successful Bidder will be notified in writing by the City of the award of the Contract within sixty (60) days after opening of Bids. Accompanying the City’s Notice of Award will be the Contract, in triplicate, which the successful Bidder will be required to execute and return, together with the Performance Bond and Payment Bond, and the required certificates and policies of insurance together with the required endorsements thereto for the Contractor and the workers compensation certificate to the City within ten (10) days following receipt of such Notice of Award. Failure to do so shall be just cause for annulment of the award and for forfeiture of the Bid Security which shall be retained as liquidated damages, and it is agreed that the bond sum is a fair estimate of the amount of damages that the City will sustain by reason of such failure. The City will promptly determine whether such Contract, Bonds and insurance are as required by the Contract Documents, and upon such determination will forward a fully executed copy of the Contract and a Notice to Proceed with the work to the successful bidder. Signature by both parties constitutes execution of the Contract. In the event of failure of the lowest

responsible Bidder to sign and return the Contract with acceptable Bonds and insurance as prescribed herein, the City may award the Contract to the next lowest responsible bidder, and, in the event that Bidder fails to sign and return the Contract with acceptable Bonds and insurance, the City may award the Contract to the then next lowest responsible bidder, etc.

20. Return of Bid Securities

All Bid Securities will be held until the Contract has been finally executed, after which all Bid Securities, other than any Securities which have been forfeited, will be returned to the respective bidders.

21. Power of Attorney

The Attorney-in-Fact (resident agent) who executes the Performance Bond and Payment Bond on behalf of the surety company must attach a copy of its Power of Attorney as evidence of its authority. A notary shall acknowledge the power as of the date of the execution of the surety bond which it covers.

22. Time of Completion

The time of completion of the work to be performed under this Contract is the essence of the Contract. Delays and extensions of time may be allowed in accordance with the provisions of the General Conditions. The time allowed for the completion of the work is stated in the Contract.

23. Licensing and Registration Requirements for Contractors

All bidders, including general contractors and specialty contractors, shall hold such licenses as may be required by the laws of the State of California for the performance of the work specified in the Contract Documents.

All bidders, and Subcontractors subject to Public Contract Code section 4104, must have registered with the California State Department of Industrial Relations pursuant to Labor Code section 1725.5 prior to submitting a bid. Furthermore, a Contractor, and all Subcontractors subject to Public Contract Code section 4104, must be registered pursuant to Labor Code section 1725.5 before entering into a contract to work on a public project.

24. Escrow of Bid Documents

Upon award of the job to the successful bidder, and at the time of execution of this Contract, Contractor shall present all documentation used by the successful Bidder in arriving at the Bid upon which the Contract was awarded ("Bid Documentation") to the City of Marysville. Such documentation shall be presented in a sealed envelope or box. Notice to Proceed will not be granted until City receives notice that such documentation has been received. This Bid Documentation shall include, but not be limited to any documents, pictures, or writings which relate to, arise out of, or constitute in any way notes, memoranda, phone logs, Subcontractor and materialmen estimates, computations, or the like used by, complied by, or drafted by the successful Bidder or its agents in arriving at its Bid for the Project. The City Construction Manager and Project Manager may consult the Bid Documents as needed during the course of the Project and in connection with the resolution of all such disputes. After Project Completion and payment and the resolution of such disputes, the Bid Documents will be returned to the Contractor.

25. **Prevailing Wages**

Copies of the current schedules for prevailing wages are on file in the City's office, and the contents of those schedules are included herein as if set forth in full. Copies of the prevailing rate of per diem wages may also be obtained from the Department of Industrial Relations, P.O. Box 420603, San Francisco, CA 94142-0603, Attn: Chief, Division of Labor Statistics and Research or online at: <http://www.dir.ca.gov/oprl/dprevagedetermination.htm>.

26. **Preconstruction Conference**

A preconstruction conference will be convened after the Contractor has delivered the necessary bonds, insurance certificates and signed agreement in proper form as required in the Request for Qualification and Proposal, Bid proposal and general conditions of these specifications. Prior to any work, the Contractor shall provide the City with a list of key personnel assigned to the project and the telephone numbers where they may be reached at any time. The list shall be made available in sufficient copies and presented at the preconstruction conference.

27. **Defined Terms**

The defined terms in the Construction Documents have the same meaning as those set forth in the General Conditions, Article 1.03.

BIDDER'S CHECKLIST

All items on the Bidder's Checklist must be initialed, dated and submitted for the Proposal to be considered complete. The City of Marysville reserves the right to award a Contract in a manner and on the basis which will best serve the City, taking into consideration the information in the statement of Bidder's qualifications and past work history with the City.

The Bidder's attention is especially called to the following items which must be executed in full as required:

1. **BID PROPOSAL**

A proposal is to be created and signed by the Bidder.

Initial: _____ Date: _____

2. **BID SECURITY**

The Bid bond is to be executed by the Bidder and the surety company unless Bid is accompanied by cash or certified check. The amount of this Bid bond shall be not less than ten percent (10%) of the total amount Bid and may be shown in dollars or on a percentage basis.

Initial: _____ Date: _____

3. **NON-COLLUSION DECLARATION**

A Non-Collusion Declaration must be filled out, signed, and submitted with the Bid proposal for the Bid documents to be considered complete.

Initial: _____ Date: _____

4. **EXPERIENCE QUALIFICATIONS**

A statement of the Bidder's Experience & Qualifications (page 1-20) must be filled out, signed, and submitted with the Bid proposal for the Bid documents to be considered complete.

Initial: _____ Date: _____

5. **DESIGNATION OF SUBCONTRACTORS**

A Designation of Subcontractors must be filled out and submitted with the Bid proposal for the Bid documents to be considered complete.

Initial: _____ Date: _____

6. **INSURANCE**

The insurance requirements, Section 6.24 of the General Conditions, for this project have been read and understood.

Initial: _____ Date: _____

7. **SITE VISIT**

The Bidder certifies that it has toured the project site and is familiar with the work involved.

Initial: _____ Date: _____

8. **PERFORMANCE AND PAYMENT BONDS (IN PART 2)**

The Bidder understands that a performance bond issued by an approved surety equaling one hundred percent (100%) of the Contract amount will be required. A payment bond equaling one hundred percent (100%) of the Contract amount will also be required.

Initial: _____ Date: _____

9. **WORK SCHEDULE**

The City makes no guarantee as to the method of work chosen by the Bidder. It is the Bidder's responsibility to plan and schedule the work in order to complete the work in the time specified in the Special Provisions.

Initial: _____ Date: _____

10. **ADDENDA**

The Bidder acknowledges that it must sign and attach any applicable Addenda to the Bid proposal.

Initial: _____ Date: _____

11. **CONTRACTOR'S CERTIFICATE REGARDING WORKERS COMPENSATION (IN PART 2)**

The Bidder acknowledgment that Worker's Compensation Insurance will be required for this project.

Initial: _____ Date: _____

12. **Attachment 1 - Customer Reference Form**

A statement of the Bidder's work history, references, and project value are part of the Bidder's qualification criteria, which must be filled out, signed, and submitted with the Bid proposal for the Bid documents to be considered complete.

Initial: _____ Date: _____

BID PROPOSAL

Proposal to: Jim Shadd, City Manager
City of Marysville
526 C Street
Marysville, CA 95901

The undersigned Bidder hereby proposes to furnish and deliver all design, necessary labor, tools, equipment, and other means of construction to perform the work required for the completion of the project entitled “**CITY HALL WINDOW REPLACEMENT PROJECT**” in accordance with the intent of all plans, specifications, and Addenda issued by the City of Marysville prior to the opening of the Bid proposals.

Bidder has read the accompanying instructions to Bidders, has carefully examined the location(s) of the proposed work, and has examined all Contract Documents, drawings and Addenda issued by the City and will contract with the City to design and construct the project, complete and in satisfactory condition.

The Bidder further agrees to complete all work required under the Contract within **Sixty (60)** working days from the date designated in the Notice to Proceed, and to accept in full payment therefore the price indicated on the Bid Schedule.

The Bidder acknowledges that it understands that a waiting period from time of Bid opening until award may be sixty (60) days during which time Bidder may not withdraw its bid. The Bidder further acknowledges that it has adjusted its Bid price to include all possible items which may influence the proposal during the waiting period. Requests for Bid price change due to the delay shall not be agreed to by the City.

Company Name: _____
Bidder's Name (Printed): _____
Bidder's Title: _____

Bidder's Signature: _____
Date: _____

Address: _____

Phone Number: _____

Contractor's License Number: _____
Classification: _____
Expiration Date: _____
Public Works Contractor
Registration Number: _____

BID SECURITY

THAT WE, THE UNDERSIGNED, _____, as principal; and _____, as Surety, are hereby held and bound unto the CITY OF MARYSVILLE, hereinafter "City", in the sum of _____ dollars (\$_____), which sum is equal to at least ten percent (10%) of the total amount of the Bid for the work, payment of which sum, well and truly to be made, we hereby jointly and severally bind ourselves, our heirs, executors, administrators, successors, and assigns.

The condition of the above obligation is such that whereas the Principal has submitted to the City a certain Bid, attached hereto and made a part hereof, to enter into a Contract, in writing, for the construction of: **CITY HALL WINDOW REPLACEMENT PROJECT** NOW, THEREFORE,

- a) If the Bid is rejected, or in the alternative,
- b) If the Bid is accepted and the Principal shall sign and deliver a Contract, in the form of a Contract attached hereto (all completed in accordance with said Bid and Contract), and shall in all other respects perform the agreement created by the Acceptance of said Bid;

Then, this obligation shall be void, otherwise the same shall remain in force and effect; it being expressly understood and agreed that the liability of the Surety for any and all default of the Principal hereunder shall be the amount of this obligation as herein stated.

The Surety, for value received, hereby stipulates and agrees that the obligations of said Surety and its bond shall be in no way impaired or affected by any extension of the time within which the City may accept such bid, and said Surety does hereby waive notice of any such extension.

IN WITNESS THEREOF, the above-bounded parties have executed this instrument under their several seals this _____ day of _____, 20____, the name and corporate seal of each corporate party being hereto affixed and those present duly signed by its undersigned representative, pursuant to authority of its governing body.

IN PRESENCE OF:

(Address)

(Address)

(Business Address)

Affix

(Individual Principal)

(Business Address)

(Individual Principal)

(Business Address)

(Corporate Principal)

(Business Address)

Affix

(Corporate Seal)

ATTEST:

(Corporate Surety)

(Business Surety)

Affix

(Corporate Seal)

The rate of premium on this bond is _____ per thousand. Total amount of premium charged \$ _____.

EXPERIENCE & QUALIFICATIONS

The Bidder has been engaged in the contracting business under the present business name for _____ years. Experience in work of a nature similar to that covered in the proposal extends over a period of _____ years.

The Bidder, as a Contractor, has never failed to satisfactorily complete a Contract awarded to it, except as follows:

Use ATTACHMENT 1 – Customer Reference Form to list contracts that have been satisfactorily completed in the last five (5) years for the persons, firm or authority indicated, and to whom reference is made.

The following is a list of plant and equipment owned by the Bidder, which is available for use on the proposed work as required.

Quantity	Name, Type and Capacity	Condition	Location
_____	_____	_____	_____
_____	_____	_____	_____
_____	_____	_____	_____
_____	_____	_____	_____
_____	_____	_____	_____
_____	_____	_____	_____
_____	_____	_____	_____

Bidder's Name (Printed): _____

Bidder's Signature: _____
(Same Signature as on Proposal)

Bidder's Title: _____

Date: _____

DESIGNATION OF SUBCONTRACTORS

In compliance with Sections 4100-4114 of the California Public Contract Code each Bidder shall submit the name, Contractor license number, public works Contractor registration number, and business location of each Subcontractor who will perform work or labor or render service to the Contractor for the construction of the work performed under these specifications in excess of one-half of one percent of the prime Contractor's total bid, or, in the case of bids or offers for the construction of streets or highways, including bridges, in excess of one-half of 1 percent of the prime Contractor 's total Bid or ten thousand dollars (\$10,000.00), whichever is greater. If the Contractor fails to specify a Subcontractor for any portion of the work to be performed under the Contract, it shall be deemed to have agreed to perform such portion itself, and it shall not be permitted to subcontract that portion of the work except under the conditions hereinafter set forth. (Attach additional forms as necessary)

Name Subcontractor	Street Address of Shop, Mill or Office	Types of Work/Category of Contract	\$ Value of Work to be Performed	Subcontractor's License Number	License Type/Exp. Date	Public Works Contractor Registration Number

If no Subcontractors will be used, write "None" here: _____

I declare under penalty of perjury that the foregoing is true and correct and this Declaration is executed this _____ day of _____, 20____, in Marysville, CA 95901.

By: _____

Contractor Company Name: _____

SUBCONTRACTOR FORM MUST BE RETURNED WITH BID

PART 2 CONTRACT DOCUMENTS

CONSTRUCTION CONTRACT

THIS CONTRACT made on _____ by and between the City of Marysville (“City”), and _____, hereinafter “Contractor”. The City and Contractor may be collectively referred to as the “parties”.

The parties have mutually covenanted and agreed as follows:

1. THE CONTRACT DOCUMENTS:

The complete Contract consists of the following documents (“Contract Documents”):

Request for Qualification and Proposal (See Part 1)
Accepted Bid (and all accompanying documents)
Addenda Nos. _____, as issued
Designation of Subcontractors, (See Part 1)
Construction Contract (See Part 2)
Payment Bond to accompany Contract (See Part 2)
Performance Bond to accompany Contract (See Part 2)
Contractor’s Certification Regarding Workers’ Compensation (See Part 2)
General Conditions (See Part 3)
Supplemental Conditions (Special Provisions) (See Part 4)
Drawings
Technical Specifications (See Part 4)
Change Orders
City of Marysville Standard Specifications 2002, with Amendments #1 & #2

2. THE WORK:

The Contractor agrees to furnish all tools, equipment, apparatus, facilities, labor, transportation, and material necessary to perform and complete in a good and workmanlike manner, the CITY HALL WINDOW REPLACEMENT “Project” as called for, and in the manner designated in, and in strict conformity with, the Contract Documents. It is understood and agreed that the tools, equipment, apparatus, facilities, labor, transportation, and material shall be furnished and the work performed and completed as required in the Drawings and Specifications under the sole direction and control of the Contractor, and subject to inspection and approval of the City, or its representatives. The City hereby designates as its representative for the purpose of this Contract the following named person: [NAME].

3. CONTRACT PRICE:

The City agrees to pay and the Contractor agrees to accept, in full payment for the work above agreed to be done, the sum of [WRITTEN NUMBER] [(NUMBER)] for the Project subject to additions and deductions as provided in the Contract Documents.

4. COMPLETION DATE:

The Project shall be commenced on the date specified in the Notice to Proceed. The total project will be completed within [WRITTEN NUMBER] [(NUMBER)] working days, as defined in the General Conditions, after the date stated in the Notice to Proceed.

5. NOTICE AND SERVICE THEREOF:

Any notice from one party to the other under the Contract shall be in writing and shall be dated and signed by the party giving such notice or by a duly authorized representative of such party. Any such notice shall not be effective for any purpose whatsoever unless served in the following manner, namely:

(a) If the notice is given to the City, by personal delivery thereof to the City Manager, or by depositing the same in the United States mail, enclosed in a sealed envelope, postage prepaid, and certified; addressed to the City at:

Jim Schaad, City Manager
City of Marysville
526 C Street
Marysville, CA 95901

(b) If the notice is given to the Contractor, by personal delivery thereof to said Contractor or to its duly authorized representative at the site of the project, or by depositing the same in the United States mail, enclosed in a sealed envelope, postage prepaid, and certified; addressed to the Contractor at:

Business _____
Attention _____
Street Address _____
City, State, Zip Code _____

(c) If the notice is given to the surety or any other person, by personal delivery to such surety or other person, or by depositing the same in the United States mail, enclosed in a sealed envelope, addressed to such surety or other person, as the case may be, at the address of such surety or person last communicated by it to the party giving the notice, postage prepaid and certified.

6. LIQUIDATED DAMAGES:

Liquidated damages as provided for in the General Conditions of the Contract shall be in the sum of One Thousand Dollars (\$1,000.00) for each and every day as defined therein for each different scope of work as defined by the Base Bid and each change order except as otherwise specified in the Supplemental Conditions.

7. PREVAILING WAGE:

Copies of the prevailing rate of per diem wages as determined by the Director of the Department of Industrial Relations in accordance with Labor Code section 1773.2 are on file at the City, and copies are available for inspection at that office to any interested party on request. Bidders shall be responsible for verifying with the Director of the Department of Industrial Relations that all such copies of the prevailing rate provided by the City are current and accurate. The requirement to pay the wage rate so specified is further detailed in the General Conditions.

8. CONTRACTOR REGISTRATION

By the execution of this Contract, Contractor hereby certifies that it is registered with the California Department of Industrial Relations as required pursuant to Labor Code section 1725.5 (Contractor registration).

IN WITNESS WHEREOF, four (4) identical counterparts of this Contract, each of which shall for all purposes be deemed an original, have been duly executed by the above-named parties, on the date noted on the first page of this Contract.

_____ Date

_____ Contractor

_____ Date

_____ Jim Schaad, City Manager
City of Marysville

Approved as to form:

_____ Brant Bordsen, City Attorney

Attest:

_____ Maggie Sanchez, City Clerk

PERFORMANCE BOND

The CITY OF MARYSVILLE, hereinafter "City," entered into a Contract dated _____, 20__ with _____ hereinafter "Contractor," for the work described as follows:

CITY HALL WINDOW REPLACEMENT PROJECT

WHEREAS, said Contractor is required under terms of said Contract to furnish a bond for the faithful performance of said Contract; and

WHEREAS, the Contract is by reference made a part hereof.

NOW, THEREFORE, we, _____, the undersigned Contractor, as Principal, and _____ (corporate surety), a corporation organized and existing under the laws of the State of _____, and duly authorized to transact business under the laws of the State of California, as Surety, are held and firmly bound unto the City in the penal sum of [WRITTEN NUMBER] [(NUMBER)], lawful money of the United States, said sum being not less than one hundred percent (100%) of the total Contract amount, for the payment of which sum be made, we bind ourselves, our heirs, executors, administrators, and successors, jointly and severally, firmly by these presents.

THE CONDITION OF THIS OBLIGATION IS SUCH, THAT, if the above-bounded Contractor, its heirs, executors, administrators, successors or assigns, shall in all things stand to and abide by, and perform the covenants, conditions, and agreements in said Contract and any alterations thereof made as therein provided, on its part, to be kept and performed at the time and in the manner therein specified, and in all respects according to their true intent and meaning, and shall indemnify and save harmless the City, its officers and agents, as therein stipulated, then this obligation shall become null and void; otherwise it shall be and remain in full force and virtue.

As a condition precedent to the satisfactory completion of said Contract, the above obligation in said amount shall hold good for a period of one (1) year after the completion and Acceptance of said work, during which time if the above-bounded Contractor, its heirs, executors, administrators, successors or assigns shall fail to make full, complete, and satisfactory repair and replacements or totally protect the City from loss or damage made evident during said period of one (1) year from the date of Acceptance of said work, and resulting from or caused by defective materials or faulty workmanship in the prosecution of the work done, the above obligation in said sum shall remain in full force and effect. However, anything in this paragraph to the contrary notwithstanding, the obligation of the Surety hereunder shall continue so long as any obligation of the Contractor remains.

And the Surety, for value received, hereby stipulates and agrees that no change, extension of time, alteration or addition to the terms of the Contract or to the work to be performed thereunder or the specifications accompanying the same shall, in any way, affect its obligations on this bond and it does hereby waive notice of any such change, extension of time, alteration, or addition to the terms of the Contract or to the work or the specifications. Said Surety hereby waives the provisions of Sections 2819 and 2845 of the Civil Code of the State of California.

In the event suit is brought upon this bond by the City and judgment is recovered, the Surety shall pay all costs incurred by the City in such suit, including reasonable attorneys' fees to be fixed by the Court.

IN WITNESS WHEREOF, we have hereunto set our hands and seals this
_____ day of _____, 20____.

(Seal)

By

(Contractor as Principal)

(Seal)

By

NOTE: If Contractor is a Partnership, all parties must execute the Bond.

IMPORTANT: Surety companies executing Bonds must appear on the Treasury Department's most current list (Circular 570 as amended) and be authorized to transact business in California.

PAYMENT BOND

The CITY OF MARYSVILLE, hereinafter "City," has awarded to _____, hereinafter "Contractor," a Contract for the work described as follows:

CITY HALL WINDOW REPLACEMENT

WHEREAS, the Contractor is required by the Contract and by the provisions of Third Division, Part 4, Title 15, Chapter 7 of the Civil Code to furnish a bond in connection with the Contract, as hereinafter set forth.

NOW, THEREFORE, we, _____, the undersigned Contractor, as Principal, and _____, a corporation organized and existing under the laws of the State of _____ duly authorized to transact business under the laws of the State of California, as Surety, are held and firmly bound unto the _____ in the sum of [WRITTEN NUMBER] [(NUMBER)], said sum being not less than one hundred (100) percent of the total Contract amount payable by the City, under the terms of the Contract, for which payment well and truly to be made, we bind ourselves, our heirs, executors and administrators, successors and assigns, jointly and severally, firmly by these presents.

THE CONDITION OF THIS OBLIGATION IS SUCH, THAT, if the Contractor, its heirs, executors, administrators, successors, and assigns or Subcontractors shall fail to pay for any materials, provisions, provender or other supplies or teams, implements or machinery used in, upon, for or about the performance of the work contracted to be done, or shall fail to pay for any work or labor thereon of any kind, or shall fail to pay any persons named in Civil Code section 9100, or shall fail to pay for amounts due under the Unemployment Insurance Code with respect to such work or labor thereon of any kind, or shall fail to pay for any amounts required to be deducted, withheld, and paid over to the Employment Development Department from the wages of employees of the Contractor and Subcontractors pursuant to Section 13020 of the Unemployment Insurance Code with respect to such work or labor, and provided that the claimant shall have complied with the provisions of that code, the Surety or Sureties hereon will pay for the same in an amount not exceeding the sum specified in the Contract; otherwise, the above obligation shall be void. In case suit is brought upon this bond, the Surety will pay reasonable attorneys' fees to the prevailing party to be fixed by the court.

This bond shall insure to the benefit of any and all persons, companies and corporations entitled to file claims under Section 9100 of the Civil Code, so as to give a right of action to them or to their assigns in any suit brought upon this bond.

It is further stipulated that the Surety of this bond shall not be exonerated or released from the obligation of the bond by any change, extension of time for performance, addition, alteration, or modification in, to, or of any contract, plans, specifications, or agreement pertaining or relating to any scheme or work of improvement described above or pertaining or relating to the furnishing of labor, materials, or equipment therefor, nor by any change or modification of any terms of payment or extension of the time for any payment pertaining or relating to any scheme or work of improvement described above, nor by any rescission or attempted rescission of the Contract, agreement, or bond, nor by any conditions precedent or subsequent in the bond attempting to limit the right of recovery of claimants otherwise entitled to recover under any such contract or agreement or under the bond, nor by any fraud practiced by any person other than the claimant seeking to recover on the bond, and that this bond be construed most strongly against the Surety and in favor of all persons for whose benefit such bond is given, and under no circumstances shall Surety be released from liability to those for

whose benefit such bond has been given, by reason of any breach of contract between the City and original Contractor or on the party of the obligee named in such bond, but the sole conditions of recovery shall be that claimant is a person described in Section 8400 and 8402 of the California Civil Code and has not been paid the full amount of its claim and that Surety does hereby waive notice of any such change, extension of time, addition, alteration, or modification.

IN WITNESS WHEREOF, we have hereunto set our hands and seals this _____ day of _____, 20__.

(Contractor as Principal)

(Seal) By _____

(Seal) By _____

NOTE: If Contractor is a Partnership, all partners should execute Bond.

IMPORTANT: Surety companies executing Bonds must appear on the Treasury Department's most current list (Circular 570 as amended) and be authorized to transact business in California.

CONTRACTOR'S CERTIFICATE REGARDING WORKER'S COMPENSATION

TO: Jim Schaad, City Manager
City of Marysville
526 C Street
Marysville, CA 95901

I am aware of the provisions of Section 3700 of the Labor Code of the State of California which require every employer to be insured against liability for Workers' Compensation or to undertake self-insurance in accordance with the provisions of that code, and I will comply with such provisions before commencing the performance of the work of this Contract.

(Contractor)

By _____

(Business Address)

(Place of Residence)

PART 3 GENERAL CONDITIONS

PART 3: GENERAL CONDITIONS

SECTION 1

DEFINITIONS AND TERMS

1.01. GENERAL

Wherever the following abbreviations and terms, or pronouns in place of them, are used in these Conditions and other Contract Documents of which these Conditions are a part, the intent and meaning shall be interpreted as provided below.

1.02. ABBREVIATIONS

The following abbreviations may be used in the Contract Documents:

AA	Aluminum Association
AASHTO	American Association of State Highway/Transportation Officials
ABMA	American Boiler Manufacturer's Association
ACI	American Concrete Institute
AFBMA	Anti-Friction Bearing Manufacturers Association
AGA	American Gas Association
AGC	Associated General Contractors
AGMA	American Gear Manufacturer's Association
AI	The Asphalt Institute
AIA	American Institute of Architects
AIEE	American Institute of Electrical Construction Managers
AISC	American Institute of Steel Construction
AISI	American Iron and Steel Institute
ANSI	American National Standards Institute, Inc.
APA	American Plywood Association
API	American Petroleum Institute
APWA	American Public Works Association
ARA	American Railway Association
AREA	American Railway Construction Managerring Association
ASCE	American Society Civil Construction Managers
ASHRAE	American Society of Heating, Refrigeration and Air Conditioning Construction Managers
ASME	American Society of Mechanical Construction Managers
ASTM	American Society for Testing and Materials
AWG	American Wire Gage
AWPA	American Wood Preservers' Association
AWS	American Welding Society
AWWA	American Water Works Association
BHMA	Builders Hardware Manufacturers Association
CCMTC	California Concrete Masonry Technical Committee
CRSI	Concrete Reinforcement Steel Institute
ETL	Electrical Testing Laboratory
FS	Federal Specification
ICBO	International Conference of Building Officials
IEEE	The Institute of Electrical and Electronics Construction Managers
IES	Illuminating Construction Managerring Society
IPCEA	Insulated Power Cable Construction Managers Association

JICS	Joint Industry Conference Standards
MBMA	Metal Building Manufacturer's Association
MSS	Manufacturers Standardization Society of the Valve and Fitting Industry Standards
NBFU	National Board of Fire Underwriters
NBS	National Building Standards
NEC	National Electrical Code
NEMA	National Electrical Manufacturers Association
NFPA	National Fire Protection Association
OSHA	Occupational Safety and Health Act of 1970
PCA	Portland Cement Association
SMACNA	Sheet Metal and Air Conditioning Contractor's National Association
SSPC	Steel Structures Painting Council
SSPWC	Standard Specifications for Public Works Construction
UBC	Uniform Building Code
UL	Underwriter's Laboratory
UMC	Uniform Mechanical Code
UPC	Uniform Plumbing Code
USAS	The United States of America Standard Institute
USBR	United States Bureau of Reclamation
USPHS	United States Public Health Service
WCLIB	West Coast Lumber Inspection Bureau
WIC	Woodwork Institute of California

1.03. DEFINITIONS

The intent and meaning of the following, wherever they appear in the Contract Documents, shall be interpreted as follows:

Acceptance - The formal Acceptance by the Construction Manager of the entire Contract, which has been completed in all respects in accordance with the Specifications and any, approved modifications.

Addenda - Any written change, clarification or supplement to documents issued for bidding, issued by the City or its Construction Manager prior to bid.

As Approved - The words "as approved", unless otherwise qualified, shall be understood to be followed by the words "by the Construction Manager".

As Shown, and As Indicated - The words "as shown" and "as indicated" shall be understood to be followed by the words "on the Plans".

Award - The decision of the City Council to accept the proposal of the lowest responsible Bidder for the Work, subject to the execution and approval of a satisfactory contract therefore and bond to secure the performance thereof and to such other conditions as may be specified or required by law.

Bid - The offer of the Bidder for the Work when made out and submitted on the prescribed Bid form, properly signed and guaranteed. A Bid is also known as a Proposal.

Bid Security - The cash, cashier's check, certified check, or bidder's bond accompanying the Bid submitted by the bidder, as a guarantee that the Bidder will enter into a Contract with the City for the performance of Work herein described.

Bidder - Any individual, firm, partnership or corporation submitting a Bid for the Work contemplated, and acting directly or through a duly authorized representative.

Bureau - United States Bureau of Reclamation.

Calendar Day - Each day shown on the calendar.

Change Order - Written order issued by the Construction Manager to the Contractor covering changes in the Contract and establishing the bases of compensation and time adjustments for work affected by the changes.

City - The City of Marysville, also referred to as the Owner.

City Council or Council - The City Council of the City of Marysville.

City Standard Details - The standard details contained in the City Standard Specifications as modified.

City Standard Specifications - 2000 edition of the City of Marysville Standard Details as amended to date of Bid submittal.

Claim - A separate demand by the Contractor for (i) a time extension, (ii) payment of money or damages arising from work done by or on behalf of the Contractor pursuant to the contract for a public work and payment of which is not otherwise expressly provided for or the claimant is not otherwise entitled to, or (iii) an amount the payment of which is disputed by the City.

Contract - The written agreement covering the performance of the work and the furnishing of labor, materials, tools and equipment in the construction of the Work. The Contract shall include all Contract Documents and supplemental agreements amending or extending the work contemplated which may be required to complete the Work in a substantial and acceptable manner. Supplemental agreements are written agreements covering alterations, amendments, or extensions to the contract and include Addenda and change orders.

Contract Documents - Contract Documents is the collective term for all of the following documents and any other document incorporated therein by reference: Request for Qualification and Proposal, Accepted Bid (and all accompanying documents), Designation of Subcontractors, Construction Contract, Payment Bond to Accompany Contract, Performance Bond to Accompany Contract, General Conditions, Supplementary and Special Conditions, (if any), Drawings (and Specifications), Addenda, Change Orders, City of Marysville Standard Specifications, Contractor's Certification Regarding Workers' Compensation.

Contractor - The person or persons, firm, partnership or corporation or other entity who has entered into the Contract with the City to perform the Work.

County - County of Yuba, California.

Date of Completion - Date of filing of the Notice of Completion with the Yuba County Clerk-Recorder's Office.

Date of Execution of the Contract - The date on which the Contract is signed by the City's authorized representative.

Datum - The Figures given in the Specifications or upon the drawings after the word "Elevation" or an abbreviation of it, shall mean U.S.G.S. datum, unless otherwise noted.

Days - Unless otherwise designated, days as used in the Contract Documents shall mean calendar days.

Elevation - The figures given on the Plans or in the other Contract Documents after the word “elevation” or abbreviation of it shall mean the distance in feet above the standard datum used by the City.

Construction Manager - The City Construction Manager, or the person designated by the City as its Construction Managing representative during the course of construction, acting either directly or through properly authorized agents, such agents acting within the scope of the particular duties delegated to them.

Extra Work - Work other than that required either expressly or implied by the Contract in its executed form.

Notice of Completion - notice of completion is the recorded project completion document filed with the Yuba County Clerk.

Or Equal - The term “or equal” shall be understood to indicate that the “equal” product be the equivalent or better than the product named in function, performance, reliability, quality, and general configuration. Determination of equality in reference to the project design requirements will be made by the Construction Manager.

Plans or Specification Drawings - The term “Plans” or “Specification Drawings” refers to the official plans, profiles, cross sections, elevations, details, and other Working Drawings and supplementary drawings, or reproductions thereof, signed by the Construction Manager, which show the location, character, dimensions, and details of the work to be performed. Plans may either be bound in the same book as the balance of the Contract Documents or bound in separate sets. Regardless of the method of binding, Plans shall be part of the Contract Documents.

Plant - All physical, resources, facilities, machinery, equipment, staging, tools, work and storage space other than provided by the Contract, together with subsidiary essentials and necessary maintenance for proper construction and acceptable completion of the project.

Project - The entire Work to be completed under the Contract.

Project Manager - The person designated by the City as its project management representative during the course of construction, acting either directly or through properly authorized agents, such agents acting within the scope of the particular duties delegated to them. The Project Manager will be the 4JCON LLC.

Shop Drawings - Drawings prepared by the fabricator or supplier showing the layout and details of components fabricated in a shop for inclusion in the permanent facility (e.g., structural steel, reinforcing steel, railings).

Site - The area upon or in which the Contractor’s operations are carried on and such other areas adjacent thereto as may be designated by the Construction Manager.

Specifications - The term “specifications” refers to the terms, provisions, and requirements contained herein. Where reference specifications, such as those of “ASTM”, “AASHTO”, etc. have been referred to, the applicable portions of such standard specifications shall become a part of these Contract Documents.

State - State of California.

State Standard Specifications - Standard Specifications issued by the State of California Department of Transportation, dated 2018, and as amended Bid in the supplemental conditions.

Subcontractor - The term “Subcontractor”, as employed herein, includes only those having a direct contract with the Contractor and it includes one who furnishes material worked to a special design according to the plans or specifications of this work, but does not include one who merely furnishes material not so worked and would be considered a supplier only.

Supplementary & Special Conditions Provisions - Additions, revisions, special directions, and requirements peculiar to a project and not otherwise thoroughly set forth in General and/or Specifications.

Time Limits - All time limits stated in the Contract Documents are of the essence of the Contract.

Work - All the work specified, indicated, shown or contemplated in the Contract Documents to construct the improvements, including all alterations, amendments or extensions thereto made by Change Order or other written orders of the Construction Manager.

Working Days - A Working day is defined as any day, except Saturdays, Sundays and legal holidays of the City.

Working Drawings - Drawings furnished by the Contractor showing the layout and details of temporary construction procedures and methods of construction, and data for construction equipment which are to be employed in the construction of the permanent facility (e.g., form drawings, erection drawings, load test pile procedures, pile hammer data, etc.).

Written Notice - “Written Notice” shall be deemed to have been duly served when delivered in person to the individual or to a member of the firm or to an officer of the corporation for whom it is intended, or if delivered at or sent by certified U.S. mail to the last business address known to the party who gives the notice as specified in the Contract.

Whenever in the Specifications or upon the drawings the words “directed”, “required”, “permitted”, “ordered”, “designated”, “prescribed”, or words of like import are used, it shall be understood that the direction, requirement, permission, order, designation or prescription of the Construction Manager is intended, and similarly the words “approved”, “acceptable”, “satisfactory”, or words of like import, shall mean approved or acceptable to, or satisfactory to the Construction Manager, unless otherwise expressly stated.

SECTION 2

SCOPE OF WORK

2.01. INTENT OF CONTRACT DOCUMENTS

The intent of the Contract Documents is to prescribe the details for the construction and completion of the Work, which the Contractor undertakes to perform in accordance with the terms of the Contract. These General Conditions are meant to replace Division I of the State Standard Specifications for all City public works contracts which incorporate these General Conditions by reference.

Where the Specifications and Plans describe portions of the Work in general terms, but not in complete detail, it is understood that only the best general practice is to prevail and that only materials and workmanship of the first quality are to be used. Unless otherwise specified, the Contractor shall furnish all labor, materials, tools, equipment and incidentals and do all the Work involved in performing the Contract in a satisfactory and workmanlike manner.

The technical provisions are presented in sections for convenience. However, this presentation does not necessarily delineate trades or limits of responsibility. All sections of the Specifications and Plans are interdependent and applicable to the Project as a whole.

The Contract Documents are complementary, and what is called for in any one shall be as binding as if called for in all. Anything shown on the Drawings and not mentioned in the Specifications or mentioned in the Specifications and not shown on the Drawings shall have the same effect as if shown or mentioned respectively in both. Any work shown on one Drawing shall be construed to be shown in all Drawings and the Contractor will coordinate the Work and the Drawings.

If any portion of the Contract Documents shall be in conflict with any other portion, the various documents comprising the Contract Documents shall govern in the following order of precedence: Change Orders; Addenda; Shop Drawings, Drawings, Supplementary and Special Conditions; Designation of Subcontractors; Construction Contract; General Conditions; City of Marysville Standard Specifications.

Detail Drawings take precedence over General Drawings. As between schedules and other information given on Drawings, the Schedules shall govern. If an item is shown on any Drawing and not specifically included in Technical Specifications specific to this project, the Drawing shall govern. Any conflict or inconsistency between or in the drawings shall be submitted to the Construction Manager for clarification as soon as the Contractor becomes aware of such inconsistency.

2.02. CONTRACTOR'S UNDERSTANDING

It is understood and agreed that the Contractor has, by careful examination, satisfied itself as to the nature and location of the Work, the conformation of the ground, the character, quality and quantity of the materials to be encountered, the character of equipment and facilities needed preliminary to and during the prosecution of the Work, the general and local conditions, and all other matters which can in any way affect the Work under this Contract. No verbal agreement or conversation with any officer, agent or employee of the City, either before or after the execution of this Contract, shall affect or modify any of the terms or obligations contained herein.

2.03. CHANGES IN THE WORK

(a) The City may, at any time, by written order, make changes in the Work as deemed necessary by the Construction Manager. Such changes include, but are not limited to:

- (1) In the Specifications or Plans;
- (2) In the sequence, method or manner of performance of the Work;
- (3) In the owner-furnished facilities, equipment, materials, services or site; and
- (4) Directing acceleration of the Work.

(b) If such changes cause an increase or decrease in the Contractor's cost of, or time required for, performance of the Contract, an equitable adjustment will be made and the Contract modified in writing accordingly.

(1) Change Orders

A change pursuant to this section will be in the form of a Change Order, which will set forth the work to be done or the method by which the change and cost adjustment, if any, will be determined, and the time of completion of the work.

Upon receipt of a Change Order, the Contractor shall proceed with the ordered work. If ordered in writing by the Construction Manager, the Contractor shall proceed with the work so ordered prior to actual receipt of a Change Order. A Change Order executed by the Contractor and approved by the Construction Manager is an executed Change Order as that term is used throughout this section.

(2) Change Order Protests

A Change Order may be issued to the Contractor at any time. Should the Contractor disagree with any terms or conditions set forth in a Change Order, which he has not executed, he shall submit a written protest to the Construction Manager within fifteen (15) days after the receipt of such Change Order. The protest shall state the points of disagreement and, if possible, the quantities and cost involved.

If a written protest is not submitted, payment will be made as set forth in the Change Order. Such payment shall constitute full compensation for all work included therein or required thereby. Such unprotested Change Orders shall be considered as executed Change Orders.

Where the protest concerning a Change Order relates to compensation, the compensation payable for all work specified or required by said Change Order to which such protest relates will be determined in the same manner as provided in Section 2.04 of this section. The Contractor shall keep full and complete records of the cost of such work and shall permit the Construction Manager to have such access thereto as may be necessary to assist in the determination of the compensation payable for such work. Where the protest concerning a Change Order relates to the adjustment of time and for completion of the Work, the time to be allowed therefor will be determined as provided in this section.

The consent of the Contractor's sureties shall not be required as to any change or Extra Work, and the liability of the Contractor's Bonds shall be increased or decreased accordingly without notice to the sureties.

2.04. PROCEDURES AND ALLOWABLE COSTS ON CHANGES AND ADDITIONS TO WORK

(a) Forms of Payment

If the change in, or addition to, the Work will result in an increase in the contract sum, the City shall have the right to require the performance thereof. The compensation to be paid for any such work shall, in the City's sole discretion, be determined in one or more of the following ways:

- (1) By extension of agreed unit prices, if unit prices are required by the City's Bid form and provided with Contractor's bid;
- (2) By revision of unit prices;
- (3) By proposal and Acceptance of an agreed upon lump sum; and
- (4) On a force account basis.

Until one of the above methods is agreed on, or if the Work is to be paid for on a time and materials basis, the Contractor shall keep full and complete records of the cost of such work in the form and manner prescribed by the Construction Manager and shall permit the Construction Manager to have access to such records as may be necessary to assist in the determination of the compensation payable for such work.

(b) Lump Sum Payment

The City, in its sole and absolute discretion, may request a lump sum proposal by Contractor to perform the change in, or addition to, the Work performed. Such lump sum proposal shall be submitted by the Contractor within ten (10) days of the City's request therefor. Request for a lump sum proposal by City shall not be deemed an election by City to have the Work performed on a lump sum basis. Costs of preparing the proposal shall not be compensable.

(1) Contents of Lump Sum Proposal

(2) The Contractor's proposal shall be itemized and segregated by labor and materials for the various components of the change (no aggregate labor total will be acceptable). The proposal shall be accompanied by signed proposals of any Subcontractors, which will perform any portion of the change, and of any persons who will furnish materials or equipment for incorporation therein. The proposal shall also include the Contractor's estimate of the time required to perform said changes or additional work.

(3) Computation of Labor Costs

The portion of the proposal relating to labor, whether by the Contractor's forces or the forces of any of its Subcontractors, may include the projected wages of the reasonably anticipated Site labor, including foremen, who will be directly involved in the change in the Work. These projected wages shall not include charges for assistant superintendents, superintendents, office personnel, timekeepers and maintenance mechanics.

Labor costs may also include Contractor's overhead and profit which shall be computed by adding to the labor costs either up to fifteen percent (15%) of the projected wages, but not payroll costs, or the labor surcharge set forth in the California Department of

Transportation publication entitled Labor Surcharge And Equipment Rental Rates, which is in effect on the date upon which the Work is accomplished and which is a part of the Contract. The method of computing the overhead and profit shall be solely within the discretion of the City.

The labor surcharge, if used, shall constitute full compensation for all payments imposed by State and Federal laws and for all other payments made to, or on behalf of, the workmen, other than actual wages as defined above. No time or charges will be allowed except when the workers are actually engaged in the proper, efficient and diligent performance or completion of the extra work as authorized. Overtime shall not be worked without prior approval of the Construction Manager.

(4) Computation of Equipment and Materials Costs

The portion of the proposal relating to materials may include the reasonably anticipated direct costs to the Contractor or to any of its Subcontractors of materials to be purchased for incorporation in the change in the Work. This portion of the proposal may also include transportation and applicable sales or use taxes. Up to fifteen percent (15%) of these direct costs may be included as overhead and profit for the Contractor or any such Subcontractor (such overhead and profit to include all small tools).

This portion of the proposal may further include the Contractor's and any of its Subcontractors' reasonably anticipated costs for the rental and operation of prime construction and automotive equipment furnished and used in connection with the change in the Work. The equipment rental and operation rates used shall be the latest edition of the Department of Transportation, Division of Construction, Equipment Rental Rates. These costs shall not include charges for listed equipment or major tools with a new cost of five hundred dollars (\$500.00) or less. No time charges shall be allowed except for equipment actually used for the proper and efficient performance or completion of the authorized change in the Work.

(5) Subcontractors

The lump sum proposal may include up to five percent (5%) of the amount, which the Contractor will pay to any of its Subcontractors for the change in the Work as allowable overhead and profit to the Contractor.

(6) Failure to Submit Lump Sum Proposal

In the event that the Contractor fails to submit its proposal within the designated period, the Construction Manager may direct the Contractor to proceed with the change or addition to the Work and the Contractor shall so proceed. The Construction Manager shall unilaterally determine the reasonable costs and time to perform the work in question, which determination shall be final and binding upon the Contractor.

(7) Failure to Agree on Lump Sum Amount

In the event that the parties are unable to agree as to the reasonable costs and time to perform the change in or addition to the Work based upon the Contractor's proposal and the Construction Manager and City do not elect to have the change in the Work performed on a time and material basis, the Construction Manager and City shall make a unilateral determination of the reasonable cost and time to perform the change in the Work, based upon their own estimates, the Contractor's submission or combination thereof. In such instances, a Change Order shall be issued for the amount of costs and time determined by the Construction Manager and the City and shall become binding upon the Contractor unless the Contractor submits its protest in writing to the City within thirty (30) days of the issuance of the Change

Order. The City has the right to direct the Contractor in writing to perform the change in the Work, which is the subject of the Change Order. Failure of the parties to reach agreement regarding the costs and time of performing the change in the Work and/or any pending protest shall not relieve the Contractor from performing the change in the Work promptly and expeditiously.

(c) Payment by Unit Prices

If any of the items included in the lump sum proposal are covered by unit prices contained in the contract document, the City may, if it requires the change in the Work to be performed on a lump sum basis, elect to use these unit prices in lieu of the similar items included in the lump sum proposal in which event an appropriate deduction will be made in the lump sum amount prior to the application of any allowed overhead and profit percentages. No overhead and profit shall be applied to any unit prices.

(d) Payment on a Force Account Basis

If the City elects to have the change or addition to the Work performed on a force account basis, the Work shall be performed, whether by the Contractor's forces or the forces of any of its Subcontractors or Sub-Subcontractors, and payment shall be made subject to the following provision. The Contractor will be paid the direct costs of the labor, equipment and materials used in performing the force account work determined as hereinafter provided.

(1) For labor, the Contractor will be paid the cost of labor for the workers (including foremen when authorized by the Construction Manager or Project Manager) used in the actual and direct performance of the work. The cost of labor, whether the employer is the Contractor or any or any Subcontractor of any tier, shall be actual wages, including basic hourly wage, health and welfare payments and pension payments incurred in performing the force account work, plus any travel and subsistence payments for the workers performing such work and made necessary thereby. To the actual wages shall be added a labor surcharge as set forth in the State Department of Transportation publication entitled "Labor Surcharge and Equipment Rental Rates", as in effect on the date the work is performed. The labor surcharge shall be deemed to encompass the City's entire liability to reimburse the Contractor for workers compensation insurance payments, social security payments, Medicare payments, federal unemployment insurance payments, state unemployment insurance payments and state training taxes, made necessary by the force account work.

(2) For equipment, the Contractor will be paid for the use of equipment at the rental rates listed for that equipment in the State Department of Transportation publication entitled "Labor Surcharge and Equipment Rental Rates", which is in effect on the date the work is performed, regardless of ownership or any rental agreement entered into by Contractor for such equipment. The rental rate paid in accord with said publication shall be deemed to include the cost of fuel, oil, lubrication, supplies, small tools, attachments, repairs and maintenance, depreciation, storage and insurance for said equipment. Rental time will not be paid when equipment is inoperable due to breakdowns, repairs or maintenance. Payment for loading, transporting and unloading time will be in accordance with the State Standard Specifications applicable to loading, transporting and unloading equipment for force account work, as applicable as of the date the equipment is loaded, transported or unloaded.

(3) For materials used in the work, the City will pay for materials furnished by the Contractor and necessarily used in the force account work. Prior to markups as set forth below, the amount paid shall be the price paid by the actual purchaser to the actual supplier plus any necessary actual costs of handling the materials.

Contractor may add fifteen percent (15%) to the total labor, equipment and material charges as the total overhead and profit to the entity or entities actually performing the force account work. If the entity or entities actually performing the work are Subcontractors or Sub-Subcontractors, the Contractor shall be allowed five percent (5%) of the total charge of the performing entity or entities (including mark-up) as Contractor's mark-up. No other mark-ups shall be allowed hereunder.

The Contractor shall submit to the City daily work and material tickets, to include the identification number assigned to the change in the Work, the location and description of the change in the Work, the classification of labor employed (and names and social security numbers), hours expended, the material used, the equipment rented (not tools) and such other evidence of cost as the City may require. The City may require authentication of all time and material tickets and invoices by persons designated by the City for such purpose. The failure of the Contractor to secure any required authentication shall, if the City elects to treat it as such, constitute a waiver by the Contractor of any claim for the cost of that portion of the Change in the Work covered by a non-authenticated ticket or invoice; provided, however, that the authentication of any such ticket or invoice by the City shall not constitute an acknowledgment by the City that the items thereon were reasonably required for the Change in the Work.

(e) Limitations on Changes

The Contractor shall not be entitled to any amount for indirect costs, damages or expenses of any nature, including, but not limited to, so-called "impact" costs, labor inefficiency, wage, material or other escalations beyond the prices upon which the proposal is based and to which the parties have agreed pursuant to the provisions of this section, and which the Contractor, its Subcontractors and Sub-Subcontractors or any other person may incur as a result of delays, interferences, suspensions, changes in sequence or the like, for whatever cause, whether reasonable or unreasonable, foreseeable or unforeseeable, or avoidable or unavoidable, arising from the performance of any and all changes in the work performed pursuant to this section. It is understood and agreed that the Contractor's sole and exclusive remedy in such event shall be recovery of its direct costs as compensable hereunder and an extension of the time of the Contract, but only in accordance with the provisions of the Contract Documents.

It is expressly agreed that Contractor shall not be entitled to claim damages for anticipated profits on any portion of the Work that may be deleted.

The amount of any adjustment for work deleted shall be estimated at the time deletion of work is ordered and the estimated adjustment will be deducted for the subsequent monthly pay estimates. The City reserves its rights under Section 3.20 to audit Contractor's as-Bid profit in connection with any deductive change, to arrive at a final adjustment. Contractor's as-Bid profit shall be reduced pro rata according to the proportion of the original contract value less as-Bid profit, represented by the work deleted.

The City reserves the right to contract with any person or firm other than the Contractor for any or all Extra Work.

2.05. UNILATERAL CHANGE IN OR ADDITION TO THE WORK

Notwithstanding the above, the City, directly or through the Construction Manager, may direct the Contractor in writing to perform changes in or additions to the scope of the Contract. The Contractor shall perform such work and the parties shall proceed pursuant to the provisions of Section 2.04.

2.06. DIFFERING SITE CONDITIONS

The Contractor shall promptly, and before the following conditions are disturbed, notify the City in writing of any:

(a) Material that the Contractor believes may be material that is hazardous waste, as defined in Section 25110.02 of the Health and Safety Code, that is required to be removed to a Class I, Class II, or Class III disposal site in accordance with provisions of existing law; or

(b) Subsurface or latent physical conditions at the Site differing from those indicated in the Contract Documents; or

(c) Unknown conditions at the Site of any unusual nature, different materially from those ordinarily encountered and generally recognized as inherent in work of the character provided for in the Contract.

The Construction Manager shall thereupon promptly investigate the conditions. If the Construction Manager finds that they do involve hazardous waste, or do materially differ and cause an decrease or increase in the Contractor's cost or time of performance, the Construction Manager will issue a change order as appropriate. Any increase or decrease of cost resulting from such changes shall be adjusted in the manner provided in Section 2.04 for adjustments as to extra and/or additional work and changes. In the event that a dispute arises between the City and the Contractor, whether the conditions materially differ, or involve hazardous waste, or cause and decrease or increase the Contractor's cost of, or time required for, performance of any part of the Work, the Contractor shall not be excused from any scheduled completion date provided by the Contract, but shall proceed with all work to be performed under the Contract, the procedures applicable to claims for extra costs shall then apply.

2.07. CLAIMS FOR EXTRA COSTS

(a) Notice of Potential Claims

(1) It is hereby mutually agreed that the Contractor shall not be entitled to the payment of any additional compensation for any cause, including any act, or failure to act, by the Construction Manager, or the happening of any event, thing or occurrence, unless the Contractor provides the Construction Manager with written notice of the potential claims as hereinafter specified. Compliance with this section, however, shall not be a prerequisite as to matters within the scope of the protest provisions in Section 2.03.

The written notice of potential claims shall set forth the reasons for which the Contractor believes additional compensation will or may be due, the nature of the costs involved, and, insofar as possible, the amount of the potential claim. The notice as above required shall be given to the Construction Manager prior to the time that the Contractor commences performance of the Work giving rise to the potential claim for additional compensation, if based on an act or failure to act by the Construction Manager, or in all other cases within ten (10) days after the happening of the event, thing or occurrence giving rise to the potential claim.

(b) Construction Dispute

(1) The Contractor may submit a dispute to the Construction Manager concerning any matter for which a protest under Section 2.03, or a notice of potential claim, is filed. Such disputes, or potential claims, shall be submitted to the Construction Manager within sixty (60) days following the submission of said protest or notice, unless, due to the nature of

the dispute or the uncompleted state of the Work, it is impracticable to determine the amount or the extent of the claim within such period. In such cases, disputes shall be submitted at the earliest practicable time in which such a determination can be made. In any event, all disputes shall be filed on or before the date of the final release by the Contractor as provided for in Section 7.09.

(2) All disputes shall be in writing and shall set forth clearly and in detail, for each item of additional compensation requested, the reasons for the dispute, reference to applicable provisions of the Specifications, the nature and the amount of the cost involved, the computations used in determining such costs, all pertinent factual data and all the documents necessary to substantiate the dispute. The Contractor shall maintain complete and accurate records of the cost or any portion of the Work for which additional compensation is claimed, and shall provide the Construction Manager with copies thereof, as required. The Construction Manager shall provide a written decision to the dispute or potential claim as soon as practicable but not later than 30 days following receipt thereof.

(c) Resolution of Construction Claims

(1) To the extent that the Contractor disputes the Construction Manager's Written Decision issued pursuant to Section 4.07(b)(2), or to the extent the Construction Manager fails to issue a timely written decision, the Contractor may file a written claim, as defined by Public Contract Code section 9204(c)(1), with the City including reasonable documentation to support the claim. Upon receipt of the claim, the City shall conduct a reasonable review of the claim, and within a period not to exceed 45 days, the City shall provide the Contractor with a written statement identifying what portion of the claim is disputed and what portion is undisputed. The time in which the City must provide a written statement may be extended by mutual agreement of the parties as specified by Public Contract Code section 9204(d)(1)(C). The City shall pay any undisputed portion of the claim within 60 days after issuance of its written statement.

(2) Claims submitted by the Contractor shall be accompanied by a notarized certificate containing the following language:

Under the penalty of law for perjury or falsification and with specific reference to the California False Claims Act, Government Code section 12650, et. seq., the undersigned,

(Name)

(Title)

(Company)

hereby certifies that the claim for the additional compensation and time, if any, made herein for the work on this contract is a true statement of the actual costs incurred and time sought, and is fully documented and supported under the contract between parties.

Dated: _____

/s/ _____

Subscribed and sworn before me this _____ day

of _____

Notary Public

My commission expires _____

Failure to submit the notarized certificate will be sufficient cause for denying the claim.

Any claim for overhead type expenses or costs, in addition to being certified as stated above, shall be supported by an audit report of any independent Certified Public Accountant. Any such overhead claim shall also be subject to audit by the City at its discretion.

Any costs or expenses incurred by the City in reviewing or auditing any claims that are not supported by the Contractor's cost accounting or other records shall be deemed to be damages incurred by the City within the meaning of the California False Claims Act.

(3) Meet And Confer Regarding Unresolved Claims. If the Contractor disputes the City's written statement issued pursuant to Section 4.07(c)(1) or if the City fails to issue a timely written response, the Contractor may demand in writing an informal conference to meet and confer for settlement of the issues in dispute. Upon receipt of a demand in writing sent by registered mail or certified mail, return receipt requested, the City shall schedule a meet and confer conference within 30 days for settlement of the dispute. The meet and confer conference shall be attended by senior executives of the parties who have authority to settle the controversy. Within 10 business days following the conclusion of the meet and confer conference, the City shall provide the Contractor with a written statement identifying the portion of the claim that remains in dispute and the portion that is undisputed. The City shall pay any undisputed portion of the claim within 60 days after it issues its written statement.

(4) Mediation. If the Contractor disputes, in writing, any portion of the City's written statement as issued under Section 4.07(c)(3), the disputed items shall be submitted to nonbinding mediation according to the provisions of Public Contract Code section 9204(d)(2), and any costs of mediation shall be allocated as set forth in that section. Upon receipt of a claim, the City and the Contractor may agree to waive, in writing, mediation.

(5) Failure to Respond or Pay. If the City fails to timely respond to a claim from the Contractor or otherwise fails to meet the time requirements of Public Contract Code section 9204, the claim shall be deemed rejected in its entirety. Additionally, amounts not timely paid in the manner required by Public Contract Code section 9204 shall bear interest at 7 percent per annum.

(6) Subcontractor Claims. If a Subcontractor or a lower tier Subcontractor lacks legal standing to assert a claim against the City because privity of contract does not exist, the Contractor may present to the City a claim on behalf of the Subcontractor or lower tier Subcontractor pursuant to Public Contract Code section 9204(d)(5).

2.08. CIVIL ACTION PROCEDURES

(a) Alternative Dispute Resolution of Claims of \$375,000.00 or Less.

(1) Claims Less Than \$375,000.00. Notwithstanding any other provision herein but after compliance with the provisions of Public Contract Code section 9204 as set

forth in Section 4.07, claims of \$375,000.00 or less shall be resolved pursuant to the alternative dispute resolution procedures set forth in Public Contract Code section 20104 *et seq.* "Claim" for this purpose means a separate demand by the Contractor for a time extension, payment of money or damages arising from work done by or on behalf of the Contractor pursuant to the Contract, for which payment is expressly provided, or the Contractor is otherwise entitled to, or an amount the payment of which is disputed by the City.

(2) Submission of Claims Less than \$375,000.00. The Contractor shall submit its claim of \$375,000.00 or less to the City in writing, within the time frames established under paragraph 4.07, but no later than before the final payment is made. The City shall respond within the time provided by statute. If the Contractor disagrees with the response or the City fails to respond within the time permitted, the Contractor shall notify the City of the disagreement in writing within fifteen (15) days from the date of the response or expiration of the time permitted to respond and demand a meet-and-confer conference. The City shall schedule a meet-and-confer conference within thirty (30) days of the demand. The meet and confer conference shall be attended by senior executives of the parties who have authority to settle the controversy. If not resolved at the meet-and-confer conference, the Contractor may initiate a civil action as set forth in Public Contract Code section 20104 *et seq.*, including but not limited to compliance with applicable Government Code provisions.

(3) Time Limits Not Extended. Nothing in subdivision (a) of Public Contract Code section 20104.2 shall extend the time limit or supersede the notice requirements provided in this Contract for filing claims by the Contractor.

(b) Alternative Dispute Resolution of Claims in Excess of \$375,000.00.

As a condition precedent to the initiation of litigation, disputes in excess of a total value of \$375,000.00 shall first be submitted to the claims procedures set forth in Sections 4.06 and 4.07.

2.09. GUARANTEE

(a) In addition to warranties, representations and guarantees stated elsewhere in the Contract Documents, the Contractor unconditionally guarantees all materials and workmanship furnished hereunder, and agrees to replace the same at its sole cost and expense, and to the satisfaction of the Construction Manager, any and all materials which may be defective or improperly installed.

(b) The Contractor shall repair or replace to the satisfaction of the Construction Manager any or all such work that may prove defective in workmanship or materials, ordinary wear and tear excepted, together with any other work, which may be damaged or displaced in so doing.

(c) In the event of failure to comply with the above stated conditions within a reasonable time, the City is authorized to have the defect repaired and made good at the expense of the Contractor who will pay the costs and charges therefore immediately upon demand, including any reasonable management and administrative costs, and Construction Managering, legal and other consultant fees incurred to enforce this section.

(d) The signing of the Contract by the Contractor shall constitute execution of the above guarantees. Except as otherwise provided in this Contract, the guarantees and warranties shall remain in effect for a period of one (1) year after final Acceptance of the Work by the City.

SECTION 3

CONTROL OF WORK

3.01. AUTHORITY OF CONSTRUCTION MANAGER

(a) The Construction Manager is the representative of the City and has full authority to interpret the Contract Documents, to conduct the construction review and inspection of the Contractor's performance, and to decide questions, which arise during the course of the Work and the Construction Manager's decisions on these matters, shall be final and conclusive. The Construction Manager has the authority to reject all work and materials, which do not conform to the Contract Documents, and has the authority to stop the Work whenever such stoppage may be necessary to insure the proper execution of the Contract. The Construction Manager's failure to stop the Work shall not obligate the City to accept defective or otherwise unacceptable work or otherwise affect the Construction Manager's or City's authority to reject work for any reason set forth in the Contract Documents.

(b) If at any time the Contractor's work force, tools, plant or equipment appear to the Construction Manager to be insufficient or inappropriate to secure the required quality of work or the proper rate of progress, the Construction Manager may order the Contractor to increase their efficiency, improve their character, to augment their number or to substitute other personnel, new or additional tools, plant or equipment, as the case may be, and the Contractor shall comply with such order. Neither the failure of the Construction Manager to demand such increase of efficiency, number, or improvement, nor the compliance by the Contractor with the demand, shall relieve the Contractor of its obligation to provide quality work at the rate of progress necessary to complete the Work within the specified time.

(c) The Construction Manager may authorize minor variations in the work from the requirements of the Contract Documents which do not involve an adjustment in the Contract Price or the Contract Time. These may be accomplished by a Field Order. Contractor shall comply promptly with all Field Orders. If the Construction Manager and Contractor are unable to agree on entitlement or on the amount or extent, if any, of any adjustment in the Contract Price or Contract time, or cost, as a result of a Field Order, a claim may be made therefor pursuant to Section 2.07.

(d) Any order given by the Construction Manager, not otherwise required by the Contract Documents to be in writing shall, on request of the Contractor, be given or confirmed by the Construction Manager in writing.

(e) Whenever work, methods of procedure, or any other matters are made subject to direction or approval, such direction or approval will be given by the Construction Manager.

3.02. DRAWINGS

(a) Drawings furnished herewith are for bidding purposes. The Construction Manager will furnish the Contractor, free of charge, copies of full size Drawings which are reasonably necessary for the execution of the Work. The Contractor shall have no claim for excusable delay on account of the failure of the Construction Manager to deliver such Drawings, unless the Construction Manager shall have failed to deliver the same within two weeks after receipt of written demand therefore from the Contractor. The Contractor shall keep one copy of said Drawings, in good order, available to the Construction Manager and the Construction Manager's representatives, and convenient to the working site.

(b) If the Contractor, in the course of the Work, finds any discrepancy between the Drawings and the physical condition of the locality, or any errors or omissions in the Drawings, or in the layout as given by points and instructions, it shall be the Contractor's duty to inform the Construction Manager in writing, and the Construction Manager will promptly verify the same.

Any work done after such discovery, until authorized, will be done at the Contractor's risk. All Drawings, Specifications, and copies thereof furnished by the Construction Manager are the property of the Construction Manager and shall not be reused on other work and, with the exception of the signed Contract sets, are to be returned to the Construction Manager, on request, at the completion of the Work. All models are the property of the City.

(c) The Drawings shall be supplemented by such Shop Drawings prepared by the fabricator and/or supplier and Working Drawings prepared by the Contractor as are necessary to adequately control the Work. No changes shall be made by the Contractor in any Shop or Working Drawings after they have been reviewed by the Construction Manager, if the Construction Manager deems that no further submittals are necessary. The Contractor shall not commence the layout, purchase, fabrication, or construction of any work for which Shop or Working Drawings are required until Construction Manager has reviewed the specifications and drawings and has indicated in writing no further submittals are required for compliance with the Contract Documents.

(d) Shop and Working Drawings for any structure shall include, but not be limited to, detail design calculations, fabrication and installation drawings, lists, graphs, operating instructions, etc., which shall be reviewed and accepted by the Construction Manager before any such work is performed.

(e) Shop and Working Drawings will be required for cribs, cofferdams, falsework, centering and form work and for other temporary work and methods of construction the Contractor proposes to use. Such Drawings shall be subject to the review and Acceptance of the Construction Manager insofar as the details affect the character of the finished work, but details of design will be left to the Contractor who shall be responsible for the successful construction of the Work.

(f) Contractor agrees that Shop and/or Working Drawings processed by the Construction Manager are not Change Orders; that the purpose of these Drawings submitted by the Contractor is to demonstrate to the Construction Manager that the Contractor understands the design concept, that the Contractor demonstrates its understanding by indicating which equipment and material the Contractor intends to furnish and by detailing the fabrication methods it intends to use. It is expressly understood, however, that favorable review of the Contractor's Shop and Working Drawings shall not relieve the Contractor of any responsibility for accuracy of dimensions and details, or for mutual agreements of dimensions and details. It is mutually agreed that the Contractor shall be responsible for agreement and conformity of its Drawings with the Specifications. Contractor further agrees that if deviations, discrepancies or conflicts between Shop and/or Working Drawings and Specifications are discovered either prior to or after the Drawings are processed by the Construction Manager, the Specifications shall control and shall be followed.

(g) Unless otherwise stated, the Construction Manager shall have thirty (30) days from the date of receipt of Shop and/or Working Drawings for review.

(h) Full compensation for furnishing all Shop and/or Working Drawings shall be considered as included in the prices paid for the Contract items of work to which such drawings relate and no additional compensation will be allowed therefore. Any cost related to the

Construction Manager's review of any particular set of Shop and/or Working Drawings more than twice, due to incompleteness or unacceptability, shall be borne by the Contractor, and the City reserves the right to withhold such costs from payments due the Contractor.

(i) All reasonable effort has been made to locate and delineate all known structures and facilities on the plans. Except as otherwise provided herein, the City of Marysville shall assume no responsibility for the completeness or accuracy of its delineation of underground utilities nor the existence of other buried objects which may be encountered, or which are not shown on the plans.

(j) The Contractor shall keep and maintain a clean set of plans for the project and shall record in red ink all changes, revisions, etc. made during the course of construction. These plans shall include all changes, revisions, etc. from the original plan complete with the exact sizes, locations, dimensions, elevations, etc. These plans shall be kept and maintained in a neat, clean and legible condition and shall be available for inspection at all times by the Construction Manager. The Contractor shall deliver these completed plans to the Construction Manager and the Construction Manager shall approve these plans prior to final Acceptance of the project by the City.

3.03. CONSTRUCTION STAKING AND SURVEYS

The City will provide one set of construction stakes and benchmarks as it deems necessary to establish lines and grades required for the completion of the site work specified in the Contract. The Contractor shall notify the Construction Manager a minimum of seven (7) days in advance of the time work is to begin on any portion of the project that may require construction staking to be provided by the City. The Contractor shall make all other surveys necessary for the completion of the Work.

Alternatively, the Construction Manager may provide the Contractor with drawings showing benchmarks and reference points as it deems necessary to establish lines and grades required for the completion of the site work specified in the Contract Documents. The Contractor shall make or furnish all surveys and set all construction stakes necessary for the completion of the work.

Stakes and marks set by the City or Construction Manager shall be carefully preserved by the Contractor. The Contractor shall be charged for the cost of replacing or restoring the stakes and marks, which are destroyed or damaged by Contractor's operation. This charge will be deducted from any monies due or to become due to the Contractor under the Contract.

3.04. PERMITS AND REGULATIONS

Permits and licenses, of a temporary nature, necessary for the prosecution of the Work shall be secured and paid for by the Contractor. Permits, licenses and easements for permanent structures or permanent changes in existing facilities shall be secured and paid for by the City unless otherwise specified.

The Contractor shall give all notices and comply with all laws, ordinances, rules and regulations bearing on the conduct of the Work as shown on the plans and described in the Specifications. Contractor shall promptly notify the Construction Manager in writing of any specification at variance therewith. In such instances, any necessary changes shall be adjusted as provided in the Contract for changes in the Work. If the Contractor performs any Work knowing it to be contrary to such laws, ordinances, rules, and regulations and without such notice to the Construction Manager, Contractor shall bear all costs arising therefrom.

3.05. CONFORMITY WITH CONTRACT DOCUMENTS AND ALLOWABLE DEVIATIONS

Work and materials shall conform to the lines, grades, cross sections, dimensions and material requirements, including tolerances, shown on Contract Documents. Although measurement, sampling, and testing may be considered evidence as to such conformity, the Construction Manager shall be the sole judge as to whether the Work or materials deviate from the Contract Documents. The Construction Manager's decision as to any allowable deviations therefrom shall be final and conclusive.

3.06. COORDINATION AND INTERPRETATION OF CONTRACT DOCUMENTS

(a) Should it appear that the Work to be done or any of the matters relative thereto are not sufficiently detailed or explained in the Specifications and Plans, the Contractor shall apply to the Construction Manager for such further explanations as may be necessary and shall conform to them as part of the Contract. In the event of any doubt or question arising respecting the true meaning of the Specifications and Plans, reference shall be made to the Construction Manager, whose decision thereon shall be final and conclusive.

(b) Any reference made in the Specifications and Plans to any specification, standard, method, or publication of any scientific or technical society or other organization shall, in the absence of a specific designation to the contrary, be understood to refer to the specification, standard, method, or publication in effect as of the date that the Work is advertised for Bids.

3.07. SUBCONTRACTORS

(a) The attention of the Contractor is directed to the provisions of California Public Contract Code sections 4100-4113 regarding subcontracting and said provisions are by this reference incorporated herein and made a part hereof.

(b) Each subcontract shall contain a suitable provision for the suspension or termination thereof should the Work be suspended or terminated or should the Subcontractor neglect or fail to conform to every provision of the Contract Documents insofar as such provisions are relevant. The Contractor shall be fully responsible to the City for the acts or omissions of the Contractor's Subcontractors and of the persons either directly or indirectly employed by the Contractor. Nothing contained in the Contract Documents shall create any contractual relationship between any Subcontractor and the City. If a legal action, including arbitration and litigation, against the City is initiated by a Subcontractor or Supplier, the Contractor shall reimburse the City for the amount of legal, Construction Managing and all other expenses incurred by the City in defending itself in said action.

(c) The City and the Construction Manager reserve the right to approve all Subcontractors.

Such approval shall be a consideration to the awarding of the Contract and unless notification to the contrary is given to the Contractor prior to the signing of the Contract, the list of Subcontractors which is submitted with the Contractor's proposal will be deemed to be acceptable. Contractor shall not, without the written consent of the City, subcontract the whole of the Work.

3.08. COOPERATION OF CONTRACTORS

(a) Should construction be under way by other forces or by other contractors within or adjacent to the limits of the Work specified or should work of any other nature be under way

by other forces within or adjacent to said limits, the Contractor shall cooperate with all such other contractors or other forces to the end that any delay or hindrance to their work will be avoided. The right is reserved to perform other or additional work at or near the site (including material sources) at any time, by the use of other forces.

(b) When two or more contractors are employed on related or adjacent work, each shall conduct its operation in such a manner as not to cause any unnecessary delay or hindrance to the other. Each Contractor shall be responsible to the other for all damage to work, to persons or property caused to the other by its operations, and for loss caused the other due to unnecessary delays or failure to finish the work within the time specified for completion.

3.09. SUPERINTENDENCE

(a) The Contractor shall designate in writing, before starting work, an individual as authorized representative who shall have the authority to represent and act for the Contractor. This authorized representative shall be present at the Site of the Work at all times while work is actually in progress on the Contract. When the Work is not in progress and during periods when the Work is suspended, arrangements acceptable to the Construction Manager shall be made for any emergency work, which may be required.

(b) The Contractor is solely responsible, at all times, for the superintendence of the Work and for its safety and progress.

(c) Whenever the Contractor or its authorized representative is not present on any particular part of the Work where it may be desired to give direction, orders will be given by the Construction Manager, which shall be received and obeyed by the superintendent or foreman who may have charge of the particular work in reference to which the orders are given.

(d) Any order given by the Construction Manager, not otherwise required by the Specifications to be in writing, will on request of the Contractor, be given or confirmed by the Construction Manager in writing.

3.10. INSPECTION OF WORK

(a) Unless otherwise provided, all equipment, materials, and work shall be subject to inspection and testing by the Construction Manager. The Construction Manager will observe the progress and quality of the Work and determine, in general, if the Work is proceeding in accordance with the intent of the Contract Documents. The Construction Manager shall not be required to make comprehensive or continuous inspections to check the quality of the Work. The Construction Manager shall not be responsible for construction means, methods, techniques, sequences, or procedures, or for safety precautions and programs in connection with the Work. Visits and observations made by the Construction Manager shall not relieve the Contractor of Contractor's obligation to conduct comprehensive inspections of the Work and to furnish proper materials, labor, equipment and tools, and perform acceptable work, and to provide adequate safety precautions, in conformance with the intent of the Contract.

(b) Whenever the Contractor varies the period during which work is carried on each day, the Contractor shall give due notice to the Construction Manager so that proper inspection may be provided. Any work done in the absence of the Construction Manager shall be subject to rejection. Proper facilities for safe access for inspection to all parts of the Work shall at all times be maintained for the necessary use of the Construction Manager and other agents of the City, and agents of the federal, state, or local governments at all reasonable hours for inspection by such agencies to ascertain compliance with laws and regulations.

(c) One or more inspectors may be assigned to observe the Work by the Construction Manager and to act in matters of construction under this Contract. It is understood that inspectors shall have the power to issue instructions and make decisions within the limitations of the authority of the Construction Manager. Such inspection shall not relieve the Contractor of the Contractor's obligation to conduct comprehensive inspections of the Work, to furnish proper materials, labor, equipment and tools, and perform acceptable work, and to provide adequate safety precautions in conformance with the intent of the Contract.

(d) The Construction Manager and the Construction Manager's representatives shall at all times have access to the Work wherever it is in preparation or progress, and the Contractor shall provide safe and convenient facilities for such access and for inspection. If the Specifications, the Construction Manager's instructions, laws, ordinances, or any public authority require any material, equipment or work to be specifically tested or approved, the Contractor shall give the Construction Manager timely notice of its readiness for inspection, and if the inspection is by an authority other than the City, of the time fixed for inspection. Inspections by the Construction Manager will be made promptly and, where practicable, at the source of supply.

(e) Work performed without inspection may be required to be removed and replaced under proper inspection. In such instances, the entire cost of removal and replacing, including the cost of City-furnished materials used in the Work, shall be borne by the Contractor, regardless of whether or not the Work exposed is found to be defective. Examination of questioned work, other than that installed without inspection, may be ordered by the Construction Manager and, if so ordered, the Work must be uncovered by the Contractor. If such work is found to be in accordance with the Contract Documents, the City will pay the cost of re-examination and replacement. If such work is found to be not in accordance with the Contract Documents, the Contractor shall pay such cost, unless the Contractor can show that the defect in the Work was caused by another Contractor, and in that event the City will pay such costs.

(f) The inspection of the Work shall not relieve the Contractor of the Contractor's obligation to fulfill the Contract as herein prescribed, or in any way alter the standard of performance provided by the Contractor, and defective work shall be made good and unusable materials may be rejected, notwithstanding that such work and materials have been previously overlooked by the Construction Manager and accepted or estimated for payment. If the Work or any part thereof shall be found defective, the Contractor shall, within ten (10) calendar days, make good such defect in a manner satisfactory to the Construction Manager. If the Contractor fails to make ordered repairs of defective work or to remove the condemned materials from the Work within ten (10) calendar days after written direction by the Construction Manager, the City may make the ordered repairs, or remove the condemned materials, and deduct the cost thereof from any monies due the Contractor.

(g) The Contractor shall furnish promptly, without additional charge, all facilities, labor and materials reasonably needed by the Construction Manager for performing all inspection and tests. Contractor shall be charged with any additional cost of inspection when material and workmanship are not ready at the time specified by the Contractor for its inspection.

(h) Where any part of the Work is being done under an encroachment permit or building permit, or is subject to federal, state, county or city codes, laws, ordinances, rules or regulations, representatives of the government agency shall have full access to the Work and shall be allowed to make any inspection or tests in accordance with such permits, codes, laws, ordinances, rules, or regulations. If advance notice of the readiness of the Work for inspection

by the governing agency is required, the Contractor shall furnish such notice to the appropriate agency.

(i) The Construction Manager may inspect the production of material, or the manufacture of products at the source of supply. Plant inspection, however, will not be undertaken until the Construction Manager is assured of the cooperation and assistance of both the Contractor and the material producer. The Construction Manager or the Construction Manager's authorized representative shall have free entry at all times to such parts of the plant as concerns the manufacture or production of the materials. Adequate facilities shall be furnished free of charge to make the necessary inspection. The City assumes no obligation to inspect materials at the source of supply.

3.11. TESTS

The Contractor shall perform, at the Contractor's own expense, all tests specified or required by the Specifications. The Construction Manager may perform such tests as the Construction Manager deems necessary to determine the quality of work or compliance with Contract Documents. The Contractor shall furnish promptly without additional charge all facilities, labor, and material reasonably required for performing safe and convenient tests as may be required by the Construction Manager. All tests by the Construction Manager will be performed in such a manner as will not unnecessarily delay the Work. The Contractor shall not be required to reimburse the City for tests performed by the City or Construction Manager. If samples of materials are submitted which fail to pass the specified tests, the Contractor shall pay for all subsequent tests.

3.12. REMOVAL OF REJECTED AND UNAUTHORIZED WORK AND MATERIALS

(a) All work or materials, which have been rejected, shall be remedied, or removed and replaced by the Contractor in an acceptable manner and no compensation shall be allowed the Contractor for such removal, replacement, or remedial work.

(b) Any work done beyond the lines and grades shown on the plans or established by the Construction Manager or any Extra Work done without written authority will be considered as unauthorized work and will not be paid for. Upon order of the Construction Manager, unauthorized work shall be remedied, removed, or replaced at the Contractor's expense.

(c) Upon failure of the Contractor to comply with any order of the Construction Manager made under this section, the City may cause rejected or unauthorized work to be remedied, removed, or replaced, and may deduct the costs therefore from any monies due or to become due the Contractor.

3.13. DEDUCTIONS FOR UNCORRECTED WORK

If the Construction Manager deems it inexpedient to correct work damaged or not done in accordance with the Contract, an equitable deduction from the Contract price shall be made therefore, and such sum may be withheld by the City from Contractor's payment.

3.14. EQUIPMENT AND PLANTS

(a) Only equipment and plants suitable to produce the quality of work and materials required will be permitted to operate on the Project.

(b) Plants will be designed and constructed in accordance with general practice for such equipment and shall be of sufficient capacity to insure the production of sufficient material to carry the Work to completion within the time limit.

(c) The Contractor shall provide adequate and suitable equipment and plants to meet the above requirements, and when ordered by the Construction Manager, shall remove unsuitable equipment from the Work and discontinue the operation of unsatisfactory plants. Contractor shall, upon request of the Construction Manager, submit one or more lists identifying, by make, model number, Contractor 's identification number and empty gross weight, each piece of operable equipment used for the Work. Contractor shall, upon request of the Construction Manager, submit documentation establishing that any measuring device used for the Work has been tested and properly approved under California Test 109.

(d) In the case of termination of this Contract before its completion for any cause whatsoever, the Contractor, if notified to do so by the City, shall promptly remove any part or all of its equipment and supplies from the property of the City. If the Contractor fails to do so, the City shall have the right to remove such equipment and supplies at the expense of the Contractor.

3.15. CHARACTER OF WORKER

If any Subcontractor, or person employed by the Contractor or any Subcontractor fails or refuses to carry out the directions of the Construction Manager or appears to the Construction Manager to be incompetent or to act in a disorderly or improper manner, said person shall be removed from the Project immediately on the requisition of the Construction Manager. That person shall not again be employed on the Work. Such discharge shall not be the basis for any claim for compensation or damages against the City, or any of its officers or agents.

3.16. SEPARATE CONTRACTS

(a) The City reserves the right to let other contracts in connection with this Work. The Contractor shall afford other contractors reasonable opportunity for the introduction and storage of their materials and the execution of their work, and shall properly connect and coordinate Contractor's work with the other Contractor 's work.

(b) If any part of the Contractor's work depends on proper execution or results upon the Work of any other Contractor , the Contractor shall inspect and promptly report to the Construction Manager any defects in such work that render it unsuitable for such proper execution and results. The Contractor's failure to inspect and report shall constitute an Acceptance of the other Contractor 's work as fit and proper for the reception of the Contractor's work, except as to defects which may develop in the other Contractor 's work after the execution of the Contractor's work.

(c) To insure the proper execution of Contractor's subsequent work, the Contractor shall measure work already in place and shall at once report to the Construction Manager any discrepancy between the executed work and the Drawings.

3.17. ASSIGNMENT

The Contractor shall not assign the Contract or sublet it as a whole or in part without the written consent of the City, nor shall the Contractor assign any monies due, or to become due to the Contractor hereafter without the prior written consent of the City.

3.18. USE OF COMPLETED PORTIONS, RIGHT TO OPERATE UNSATISFACTORY EQUIPMENT OR FACILITIES

(a) The City may, at any time, and from time to time, during the performance of the Work, enter the Work Site for the purpose of installing any necessary work by City labor or other contracts, and for other purpose in connection with the installation of facilities. In doing so, the City shall endeavor not to interfere with the Contractor and the Contractor shall not interfere with other work being done by or on behalf of the City.

(b) If, prior to completion and final Acceptance of all the Work, the City takes possession of any structure or facility (whether completed or otherwise) comprising a portion of the Work with the intent to retain possession thereof (as distinguished from temporary possession contemplating the return to the Contractor), then, while the City is in possession of the same, the Contractor shall be relieved of liability for loss or damage to such structure other than that resulting from the Contractor's fault or negligence. Such taking of possession by the City shall not relieve the Contractor from any provisions of this Contract regarding such structure, other than to the extent specified in the preceding sentence, nor shall such taking constitute a final Acceptance of such structure or facility.

(c) If, following installation of any equipment or facilities furnished by the Contractor, defects requiring correction by the Contractor are found, the City shall have the right to operate such unsatisfactory equipment or facilities and make reasonable use thereof until the equipment or facilities can be shut down for correction of defects without injury to the City.

3.19. LANDS FOR WORK, RIGHT-OF-WAY CONSTRUCTION ROADS

(a) The City will provide the lands, easements, right-of-way, and/or encroachment permits necessary or other rights to enter and work on lands necessary for the performance of the Work. Other permits and licenses are addressed by Section 3.04. Should the Contractor find it advantageous to use any additional land for any purpose whatever, the Contractor shall provide for the use of such land at its expense. The Construction Manager shall be furnished with a copy of written agreements or otherwise be notified in writing of additional working space which is acquired. Nothing herein contained and nothing marked on the Plans shall be interpreted as giving the Contractor exclusive occupancy of the territory provided by the City. When two or more contracts are being executed at one time on the same or adjacent land in such a manner that work on one contract may interfere with that on another, the Construction Manager shall decide which Contractor shall cease work, and which shall continue, or whether the work on both contracts shall progress at the same time and in what manner, and the decision of the Construction Manager shall be final and binding. When the territory of one contract is the necessary or convenient means of access for the performance of another contract, such privilege of access or any other reasonable privilege may be granted by the Construction Manager to the Contractor so desiring, to the extent, amount, in the manner, and at the time permitted. No such decision as to the method or time of conducting the Work or the use of territory shall be the basis of any claim for delay or damage.

(b) Lands, easements or rights-of-way to be furnished by the City for construction operations will be specifically shown on the Plans.

(c) The Contractor shall construct and maintain all roads necessary to reach the various parts of the Work and for the transportation thereto of construction material and personnel. The cost of constructing and maintaining such roads shall be borne by the Contractor.

3.20. CITY'S RIGHT TO AUDIT AND PRESERVATION OF RECORDS

(a) The Contractor shall maintain books, records and accounts of all costs in accordance with generally accepted accounting principles and practices. The City and its authorized representatives shall have the right to audit the books, records and accounts of the Contractor under any of the following conditions:

(1) The Contract is terminated for any reason in accordance with the provisions of the Contract Documents in order to arrive at equitable termination costs;

(2) In the event of a disagreement between the Contractor and the City over the amount due the Contractor under the terms of the Contract;

(3) To check or substantiate any amounts invoiced or paid which are required to reflect the costs of the Contractor, or the Contractor's efficiency or effectiveness under this Contract or in connection with extras, changes, claims, additions, back charges, or others, as may be provided for in this Contract;

(4) If it becomes necessary to determine the City's rights and the Contractor's obligations under the Contract or to ascertain facts relative to any claim against the Contractor which may result in a charge against the City;

(5) To determine any difference in cost occasioned by a permissible substitution;

(6) And/or for any other reason in the City's sole judgment.

(b) Contractor shall provide the City (or its representatives), unlimited, reasonable access during working hours to the Contractor's books and records. The City's audit rights shall be liberally construed in the City's favor.

(c) The Contractor, from the effective date of final payment or termination hereunder, shall preserve and make available to the City for a period of three (3) years thereafter, at all reasonable times at the office of the Contractor (but without any charge to the City), all its books, records, documents, photographs, micro-photographs, and other evidence bearing on the costs and expenses of the Contractor under this Contract and relating to the Work hereunder.

(d) The City will make all payments required of it under this Contract subject to audit, under circumstances stated above, which audit may be performed at the City's option, either during the Contract time period or during the record retention time period. Regardless of authorization, approval or acceptance, signatures or letters which are given by the City and are part of the City's control systems or are requested by the Contractor, the payments made under this Contract shall not constitute a waiver or agreement by the City that it accepts as correct the billings, invoices or other charges on which the payments are based. If the City's audit produces a claim against the Contractor, the City may pursue all its legal remedies even though it has made all or part of the payments required by this Contract.

(e) If any audit by the City or its representative discloses an underpayment by the City pursuant to the terms of the Contract Documents, the City shall have the duty to pay any amount found by the audit to be owed to the Contractor. If such audit discloses an overpayment, the Contractor shall have the obligation to reimburse the City for the amount of the overpayment. The City's right to claim reimbursement from the Contractor of any overpayment shall not be terminated or waived until three years after the completion of the City's audit or

upon the termination of audit rights under subparagraph 3.20(f), whichever date is later. The obligation of the Contractor to make reimbursements hereunder shall not terminate except as provided by law.

(f) The City's right to audit and the preservation of records shall terminate at the end of three (3) years after the date final payment is made or termination of the Contract. The Contractor shall include this "Right to Audit and Preservation of Records" clause in all subcontracts issued by it and it shall require the same to be inserted by all lower tier Subcontractors in their subcontracts, for any portion of the work. Should Contractor fail to include this clause in any such contract or lower tier contract, or otherwise fail to insure the City's rights hereunder, Contractor shall be liable to the City for all costs, expenses and attorney's fees which the City may have to incur obtaining or attempting to obtain an audit or inspection of or the restoration of records which otherwise would have been available to the City from said persons under this clause. Such audit may be conducted by the City or its authorized representative.

SECTION 4

CONTROL OF MATERIALS

4.01. MATERIALS

(a) Unless otherwise specifically stated in the Specifications, the Contractor shall furnish all materials necessary for the execution and completion of the Work. Unless otherwise specified, all materials shall be new and shall be manufactured, handled, and installed in a workmanlike manner to insure completion of the Work in accordance with the Contract Documents. The Contractor shall, upon request of the Construction Manager, furnish satisfactory evidence as to the kind and quality of materials.

(b) Where materials are to be furnished by the City, the type, size, quantity and location at which they are available will be stated in the Contract Documents.

(c) Manufacturers' warranties, guarantees, instruction sheets and parts listed, which are furnished with certain articles or materials incorporated in the Work, shall be delivered to the Construction Manager before Acceptance of the Contract.

4.02. STORAGE OF MATERIALS

Articles or materials to be incorporated in the Work shall be stored in such a manner as to insure the preservation of their quality and fitness for the Work, and to facilitate inspection.

4.03. TRADE NAMES AND ALTERNATIVES

Whenever a material, article, system or sub-system is specified or described by using the name and/or model of a proprietary product or trademark or the name of the manufacturer or vendor, the specified item shall establish the type, function, and quality required. It shall be understood that the words "or approved equivalent" are implied whether or not they follow the proprietary enumeration.

The City reserves the right to determine when proprietary items have no equivalency, and when uniformity of operations, interchangeability of parts, standard parts inventory, etc., are in the City's best interest.

Requests for review of equivalency will be considered upon submission of sufficient information as described herein, to allow complete review. Such requests shall not be accepted from anyone other than the Contractor. Such submission must be made prior to purchase, fabrication, manufacture or use of the equivalent items under consideration.

(a) **Contractor's Risk.** If the Contractor includes in its Bid or later proposes any material, product or equipment that the Contractor considers equivalent to that specified, the Contractor assumes all risk of any sort associated with Acceptance or rejection of proposed equivalent items. The Contractor shall have no right to make claim based upon Contractor's Bid that includes a proposed equivalent item(s) of work which resulted in a lower Bid amount for said item(s) or lower total bid.

(b) **Submission Requirements.** Each submission for equivalency review shall include:

(1) Justification for use of the proposed equivalent item(s), including evidence, as applicable, that Contract specified material, product or equipment is unobtainable or unobtainable within an acceptable time for contract completion;

(2) A description of the difference between specified item(s) and proposed equivalent item(s) and the comparative advantages and disadvantages of each;

(3) All relevant data addressing each specified parameter to show equivalency;

(4) A prediction of any effects the proposed change will have on operation and maintenance costs where applicable.

(c) Equivalency. An item will be considered equivalent to the item specified if it is equal to or better in:

(1) Design and strength in all sub-parts, quality, reliability and durability, operation, maintenance and serviceability, as applicable; and

(2) Specified parameters in performance in all respects for the specific function(s) indicated in the contract.

(d) Supplemental Requirements. Any tests required by the City to establish quality and performance standards shall be promptly conducted by or through the Contractor at no additional cost to the City. In addition, the Contractor shall:

(1) Submit any additional data requested by the Construction Manager for the equivalency review; and

(2) Satisfactorily accomplish all changes, including any Construction Managering associated with use of equivalent items, at no additional cost to the City.

(e) Equivalency Determinations. The Construction Manager shall be the sole judge as to equivalency determinations. The Construction Manager's decision shall be final. The Contractor shall have no right of appeal to any decision rejecting the equivalency of any item.

(f) Procedure.

(1) Data substantiating a request for a substitution of "an equal" item shall be submitted prior to the Award of the Contract pursuant to Section 3400 of the latest edition of the Public Contract Code.

(2) After the Bid opening, the apparent three low bidders shall have seven (7) calendar days to provide complete substantiating data for all product, material or system substitution requests. After this seven (7)-day period, the City may award the Contract to the apparent low bidder. In no event will product, material or system substitution requests submitted after the Award of Contract be considered. Failure to submit such substantiating data will result in the automatic rejection of the proposed substitution request. The City will have thirty (30) days to review the first ten (10) proposed substitution requests. For each additional five (5) product, material or system substitution requests over and above the initial ten (10), the City will have ten (10) additional days to review the proposed substitution requests.

(3) Each substitution request may include one alternate substitution. All alternate substitutions shall be submitted concurrently with substitution requests. Upon review

by the City, proposed substitutions shall be returned to the Bidder marked either “accepted” or “rejected”. The City shall only review alternative substitution requests if the primary substitution request is rejected. If a substitution request, and its alternative, is returned “rejected”, no further substitution requests for that product, material or system will be allowed and the Bidder will provide the specified product, material or system.

(4) If, after all substitution requests have been processed, substitution requests by the apparent low Bidder are rejected by the City, the apparent low Bidder may elect not to execute the Contract. Under no circumstances, will bidders be allowed to alter their Bid Price as originally submitted. This election shall be made in writing no later than five (5) days following the receipt of the reviewed substitution requests. An election by the Bidder not to execute the Contract will result in the forfeiture of the bidder’s Bid bond. If the apparent low Bidder elects not to continue, and the second low Bidder is awarded the Contract, the second low Bidder may then elect not to execute the Contract for the contract price shown on its Bid Form. Subsequent bidders shall have five (5) days following the receipt of the reviewed substitution requests and the Notice of Award in which to make their election. This process shall continue until one Bidder decides to continue with the Award of Contract process.

(5) The City may award the Contract at any time after the time for submitting substitution requests expires pursuant to subpart (2), above. In the event the Contract is awarded prior to acceptance/rejection of substitution requests, all outstanding substitution requests shall be reviewed by the City as provided above. If the apparent low Bidder elects not to execute the Contract, the Award of Contract to the apparent low Bidder shall be rescinded and the Contract awarded to the next apparent low bidder. All bidders electing not to execute the Contract expressly agree that the City shall incur no liability for such rescissions. As provided herein, “apparent low bidder” means the lowest responsive and responsible bidder.

4.04. CERTIFICATES OF COMPLIANCE

(a) A Certificate of Compliance shall be furnished prior to the use of any materials for which the Technical Specifications require that such a certificate be furnished. In addition, when so authorized in the Specifications, the Construction Manager may permit the use of certain materials or assemblies prior to sampling and testing if accompanied by a Certificate of Compliance. The Certificate of Compliance shall be signed by the manufacturer of the material or the manufacturer of assembled materials and shall state that the materials involved comply in all respects with the requirements of the Contract. A Certificate of Compliance shall be furnished with each lot of material delivered to the Work and the lot so certified shall be clearly identified in the Certificate.

(b) All materials used on the basis of a Certificate of Compliance may be sampled and tested at any time. The fact that material is used on the basis of a Certificate of Compliance shall not relieve the Contractor of responsibility for incorporating material in the Work which conforms to the requirements of the Contract Documents and any such material not conforming to such requirements will be subject to rejection whether in place or not.

(c) The City reserves the right to refuse to permit the use of material on the basis of a Certificate of Compliance.

(d) The form of the Certificate of Compliance and its disposition shall be as directed by the Construction Manager.

SECTION 5
LEGAL RELATIONS AND RESPONSIBILITY

5.01. COMPLIANCE WITH LAWS – PERMITS, REGULATIONS, TAXES

The Contractor is an independent Contractor and shall, at the Contractor's sole cost and expense, comply with all laws, rules, ordinances and regulations of all governing bodies having jurisdiction over the Work, obtain all necessary permits and licenses therefore, pay all manufacturers' taxes, sales taxes, use taxes, processing taxes, and all federal and state taxes, insurance and contributions for social security and unemployment which are measured by wages, salaries or any remuneration paid to Contractor's employees, whether levied under existing or subsequently enacted laws, rules or regulations. The Contractor shall also pay all property tax assessments on materials or equipment used until Acceptance by the City. If any discrepancy or inconsistency is discovered in the Plans or Specifications, or in this Contract in relation to any such law, rule, ordinance, regulation, order or decree, the Contractor shall forthwith report the same to the Construction Manager in writing. The Contractor shall also protect, defend and indemnify the City, the Construction Manager, and all of the City's officers, agents, and servants against any claim or liability arising from or based upon the violation of any such law, rule, ordinance, regulation, order or decree, whether by the Contractor or its employees. Particular attention is called to the following:

(a) Without limitation, materials furnished and performance by Contractor hereunder shall comply with Safety Orders of the Division of Industrial Safety, State of California, Federal Safety regulations of the Bureau of Labor, Department of Labor; and any other applicable Federal regulations.

(b) The Contractor, upon request shall furnish evidence satisfactory to the City and Construction Manager that any or all of the foregoing obligations have been or are being fulfilled. The Contractor warrants to the City that it is licensed by all applicable governmental bodies to perform this Contract and will remain so licensed throughout the progress of the Work, and that Contractor has, and will have, throughout the progress of the Work, the necessary experience, skill and financial resources to enable the Contractor to perform this Contract.

(c) Contractor is required to insure that material safety data sheets (MSDSs) for any material requiring a material safety data sheet pursuant to any federal or state law are available in a readily accessible place on the Project premises. Contractor is also required to insure:

(1) The proper labeling of any substance brought onto the Project premise by Contractor or any Subcontractors and

(2) That the person(s) working with the material, or within the general area of the material, are appropriately informed about the hazards of the substance and follow proper handling and protection procedures.

(d) Contractor is required to comply with the provisions of California Health and Safety Code section 25249.5, *et seq.* (Prop. 65), which requires the posting and giving of notice to persons who may be exposed to any chemical known to the State of California to cause cancer.

5.02. PREVAILING WAGE

(a) The Contractor shall forfeit as penalty to the City the amount specified by law for each calendar day or portion thereof for each worker (whether employed by the Contractor or any Subcontractor) paid less than the stipulated prevailing rates for any work done under the Contract in violation of the provisions of the Labor Code and in particular, Section 1775 which is incorporated herein by reference. Copies of the current schedules for prevailing wages are on file in the City's office, and the contents of those schedules are included herein as if set forth in full.

(b) The City will not recognize any claims for additional compensation because of the payment of the wages set forth in these General Conditions. The possibility of wage increases is one of the elements to be considered by the Contractor in determining its proposal, and will not under any circumstances, other than delays caused by the City, the Construction Manager, or the City's agents, be considered as the basis of a claim against the City.

(c) The Contractor agrees to follow the instructions of the City's labor compliance officer until notified otherwise in writing by the City.

(d) The Director of the Department of Industrial Relations of the State of California has determined the general prevailing rate of wages of per diem wages in the locality in which the work is to be performed for each craft or type of worker needed to execute the Contract. Copies of the applicable prevailing wage rate determinations are made available to the Contractor and Subcontractor at the Pre-Job Conference Meeting. The Contractor shall post a copy of this document at the prevailing wages at each job site, along with a CMU work place poster, printed on 8 1/2" X 11" paper or larger, in accordance with California Code of Regulations, Title 8, section 16451(d).

5.03. PREVAILING WAGE RECORDS

(a) The Work is subject to monitoring and enforcement of prevailing wage requirements by the Department of Industrial Relations ("DIR") and the following provisions will apply:

(1) Contractor and Subcontractors shall maintain and furnish to the DIR, a certified copy of each weekly payroll (but no less often than monthly), with a statement of compliance signed under penalty of perjury. Such certified payroll reports in PDF form shall be transmitted electronically to the DIR after first registering at <http://www.dir.ca.gov/Public-Works/Certified-Payroll-Reporting.html>. The provisions of Labor Code section 1776 are incorporated herein by reference.

(2) The CITY and the DIR shall review, including by way of job site inspections, and, if appropriate, audit payroll records to verify compliance with the public works requirements of the Labor Code. The DIR will notify the Contractor or Subcontractor(s), as appropriate) of any noncompliance, in order for all such Contractor or Subcontractor(s) to correct the noncompliance.

(3) The City shall withhold payments when payroll records are delinquent or inadequate.

(4) The City shall withhold payments equal to the amount of underpayment and applicable penalties when, after investigation, it is established that underpayment has occurred.

(5) The City shall cooperate with the DIR and DLSE in any investigation of suspected violations of prevailing wage requirements.

(6) As directed by the Labor Commissioner, the City shall withhold Contract payments equal to the payments due or estimated to be due to the Contractor or Subcontractors whose payroll records are delinquent or inadequate, plus any additional amount that the Labor Commissioner has reasonable cause to believe may be needed to cover a back wage and penalty assessment against such Contractor or Subcontractors. The Contractor shall be required to withhold payments to a Subcontractor whose payroll records are delinquent or inadequate until the Labor Commissioner provides notice that the Subcontractor has cured such delinquency or deficiency.

(7) These payroll records shall be made available to the City's representatives. These records shall be maintained during the course of the Work. The Contractor and all Subcontractors shall make the certified payroll records available for inspection by City representatives upon request and shall permit such representatives to interview employees during the work hours on the job site.

(8) The Contractor shall be held entirely responsible for the prompt resolution of all non-compliances with the prevailing wage laws, including those pertaining to all Subcontractors and any lower tier Subcontractors.

(9) The Project will not be accepted as complete by the City nor final payment made until all items of non-compliance are corrected or until appropriate provision is made by depository agreement to assure the ultimate resolution and payment of any back wages that may be found due.

(b) A pre-construction conference shall be conducted before commencement of the Work with the Contractor and Subcontractors at which time the prevailing wage requirements will be reviewed and agreed to by all parties.

5.04. LABOR DISCRIMINATION

Attention is directed to Section 1735 of the Labor Code, which reads as follows: "A Contractor shall not discriminate in the employment of persons upon public works on any basis listed in subdivision (a) of Section 12940 of the Government Code, as those bases are defined in Sections 12926 and 12926.1 of the Government Code, except as otherwise provided in Section 12940 of the Government Code. Every Contractor for public works who violates this section is subject to all the penalties imposed for a violation of this chapter."

5.05. EIGHT-HOUR DAY LIMITATION

(a) In accordance with the provisions of the Labor Code, and in particular, Sections 1810 to 1815 thereof, inclusive, eight hours labor shall constitute a day's work, and no worker, in the employ of said Contractor, or any Subcontractor, doing or contracting to do any part of the work contemplated by this Contract, shall be required or permitted to work more than eight (8) hours in any one calendar day and forty (40) hours in any one calendar week in violation of those provisions; provided that subject to Labor Code section 1815, a worker may perform work in excess of either eight (8) hours per day or forty (40) hours during any one week upon compensation for all hours worked in excess of eight (8) hours per day or forty (40) hours during any one week at not less than one and one-half times the basic rate of pay.

(b) The Contractor and each Subcontractor shall also keep an accurate record showing the names and actual hours worked of all workers employed by them in connection

with the Work. This record shall be open at all reasonable hours to the inspection of the City, State and Federal officers and agents. It is hereby further agreed that, the Contractor shall forfeit as a penalty to the City the sum of twenty-five dollars (\$25.00) for each worker employed in the performance of this Contract by the Contractor or by any of its Subcontractors for each calendar day during which such worker is required or permitted to labor more than eight (8) hours in and one calendar day and forty (40) hours in any one calendar week in violation of Sections 1810 through 1815.

5.06. COMPLIANCE WITH STATE REQUIREMENTS FOR EMPLOYMENT OF APPRENTICES

The Contractor's attention is directed to Section 1777.5 of the Labor Code. Provisions of said section pertaining to employment of registered apprentices are hereby incorporated by reference into these Specifications. As applicable, the Contractor or any Subcontractor employed by the Contractor in the performance of the Work shall take such actions as necessary to comply with the provisions of Section 1777.5.

5.07. UNDERGROUND UTILITIES

(a) In accordance with Government Code section 4215, the Contractor shall be compensated for the costs of locating, repairing damage not due to the failure of the Contractor to exercise reasonable care, and removing or relocating existing main or trunkline utility facilities which are not indicated in the Contract Plans and Specifications with reasonable accuracy, and for the equipment on the Project necessarily idled during such work, provided that the Contractor shall first notify the Construction Manager before commencing work on locating, repairing damage to, removing or relocating such utilities. Contractor shall not be assessed liquidated damages for delays in completing the Work when such delays are due to the failure of either the City or the owner of the utility to provide for removal or relocation of such utility facilities.

(b) The Contractor shall take all precautions necessary to protect the existing utilities within the project area. Any utilities damaged due to the Contractor's negligence shall be repaired or restored to their original condition at the Contractor's sole expense. Existing utilities shall be kept in service during the life of the Contract unless relocation, reconstruction, abandonment, or outage is specifically authorized by the Construction Manager.

(c) The Contractor shall provide and maintain such temporary supports as may be necessary to preserve the functions of the various utility systems. No wires, conduits and/or pipes shall be removed until all services therein have been made inoperable.

(d) The Contractor shall notify the Construction Manager and appropriate Regional Notification Center for operators of subsurface installations at least two (2) working days, but not more than fourteen (14) calendar days, prior to performing excavation or other work close to any underground pipeline, conduit, duct, wire and other structures. The Contractor shall provide updated information to the Notification Center as required and on a periodic basis. The Regional Notification Center includes but is not limited to the Underground Service Alert-Northern California (USA) at 1-800-642-2444.

(e) The Contractor is advised that the State of California does not participate in USA. The Contractor is required to notify Caltrans Permits Branch (916) 322-1297 for the location of State facilities.

(f) The Contractor shall not proceed with work until utility facilities involved have been located, disconnected, or otherwise adjusted by utility representatives.

(g) The City Utility Maintenance Division will make repairs to all water service laterals and water mains damaged by the Contractor during the course of construction unless directed otherwise by the Construction Manager. Except as otherwise provided in this section, the Contractor shall be required to pay all labor, material and equipment costs incurred by the City Utilities Maintenance Division for the repairs made to damaged water service laterals and water mains. The City will bill the Contractor for the repairs and the bills will be paid by the Contractor prior to either the next monthly progress payment or prior to the final payment, whichever comes first. The Contractor shall provide to the Construction Manager proof of payment of the repair bills prior to the issuance of either the monthly progress payment or final payment. The current labor and equipment rates for the City Utility Maintenance Division will be made available to the Contractor at the preconstruction conference. The City shall have the right to deduct the total amount of any unpaid City repair bill from the money due or to become due the Contractor.

5.08. WATER POLLUTION

The Contractor shall exercise every reasonable precaution to protect streams, lakes, reservoirs, and canals from pollution with fuels, oils, bitumens, calcium chloride, and other harmful materials and shall conduct and schedule Contractor's operations so as to avoid or minimize muddying and silting of said streams, lakes, reservoirs, and canals. Care shall be exercised to preserve vegetation beyond the limits of construction. The Contractor shall comply with Section 5650 of the California Fish and Game Code and all other applicable statutes and regulations relating to the prevention and abatement of water pollution.

5.09. PAYMENT OF TAXES

The Contract prices paid for the Work shall include full compensation for all taxes, which the Contractor is required to pay, whether imposed by federal, state, or local governments.

5.10. PERMITS AND LICENSES

The Contractor shall procure all permits and licenses, pay all charges and fees, and give all notices necessary and incident to the lawful prosecution of the work. All permits and licenses shall be obtained in sufficient time to prevent delays to the Work. The Contractor shall, at a minimum, possess and maintain the licenses and permits set forth in the Contract Provisions.

5.11. PATENTS

The Contractor shall assume all costs arising from the use of patented materials, equipment, devices, or processes used on or incorporated into the Work, and agrees to indemnify, defend and save harmless the City, the Construction Manager, and their duly authorized representatives, from all suits at law, or actions of every nature for, or on account of, the use of any patented materials, equipment, devices, or processes.

5.12. PUBLIC CONVENIENCE

This section defines the Contractor's responsibility with regard to convenience of the public and public traffic in connection with its operations.

(a) The Contractor shall so conduct its operations as to offer the least possible obstruction and inconvenience to the public. The Contractor shall have under construction no greater length or amount of work than can be properly prosecuted with due regard to the rights of the public.

(b) Unless otherwise provided in the Contract Documents, all public traffic shall be permitted to pass through the Work with as little inconvenience and delay as possible. In order to expedite the passage of public traffic through or around the work, the Contractor shall install as appropriate signs, lights, flares, barricades, and other facilities for the sole convenience and direction of public traffic. Also, where directed by the Construction Manager, the Contractor shall provide and station competent flag persons whose sole duties shall consist of directing the movement of public traffic through or around the Work. The cost of furnishing and installing such signs, lights, flares, barricades, and other facilities, and the cost of providing and stationing such flag persons, all for the convenience and direction of public traffic, will be considered as included in the Contract price and no additional compensation will be allowed.

(c) Spillage resulting from hauling operations along or across any publicly traveled way shall be removed immediately by the Contractor at its expense.

(d) Construction operations shall be conducted in such a manner as to cause as little inconvenience as possible to abutting property owners.

(e) Convenient access to driveways, houses and buildings along the line of the work shall be maintained and temporary approaches to crossings or intersecting highways shall be provided and kept in good condition. When the abutting property owner's access across the right-of-way line is to be eliminated, or to be replaced under the Contract by other access facilities, the existing access shall not be closed until the replacement access facilities are usable.

(f) Water shall be supplied if ordered by the Construction Manager for the alleviation or prevention of dust nuisance as provided in the Contract Documents. Any water obtained from a fire hydrant within the City of Marysville shall be subject to a fire hydrant permit issued by the Construction Managing Division of the City of Marysville.

(g) Flag persons and guards, while assigned to traffic control, shall perform their duties and shall be provided with the necessary equipment in accordance with the current "Instructions to Flagmen" of the California Department of Transportation. The equipment shall be furnished and kept clean and in good repair by the Contractor at its expense.

(h) All traffic control shall be in accordance with California Manual on Uniform Traffic Control Devices (California MUTCD), Part 6 and this Section 5.12.

(1) Traffic Control Plans. Traffic Control Plans shall be developed for the project to assure that adequate consideration is given to the safety and convenience of motorists, pedestrians, and workers during construction. The Traffic Control Plans shall include, but not be limited to, signing, pavement markings, construction scheduling, permanent barricades, methods and devices for delineation and channelization, placement and maintenance of devices, roadway lighting, traffic regulations, surveillance and inspection. The Traffic Control Plans shall be approved by the Construction Manager a minimum of two (2) working days prior to start of any work. Non-compliance with any stipulation of this section will be justification for the City to stop work.

(2) Traffic Control Devices and Procedures. Traffic control devices and procedures shall conform to the California Manual on Uniform Traffic Control Devices (California MUTCD), Part 6 and this Section 5.12. Non-compliance with any stipulation of this section will be justification for the City to stop work.

(3) Elimination of On-Street Parking. The Contractor shall place notification for the elimination of on-street parking, if required, at least forty-eight (48) hours, but not more

than seventy-two (72) hours prior to the start of work. The notification shall include the Contractor's phone number, the City of Marysville Community Development Department phone number (916) 617-4645, and the phrase "VEHICLES WILL BE TOWED PURSUANT TO CVC SECTION 22651 (L)". This notice shall be affixed to a Type II barricade that is placed in the lane of the road (max. 200 ft. spacing) used for on-street parking. No other location or method of placement is acceptable. The notification shall be in a form approved by the Construction Manager. Non-compliance with any stipulation of this section will be justification for the City to stop work.

(4) Lane Closures. All lane closures shall be included in the Traffic Control Plans, and shall both conform to Section 5.12(h)(2) above, and be approved by the Construction Manager. Total road closures will not be allowed for the Project.

(5) Measurement and Payment. Unless specifically shown as an item of work on the proposal form, all traffic control shall be considered included in other items of work and no additional compensation will be made for labor, materials or equipment needed.

5.13. CONTINUOUS OPERABILITY OF FACILITIES

Absent written permission by the Construction Manager, the continuous operation of all existing facilities is required and shall in no way be affected by the Work.

5.14. SAFETY

(a) General

(1) The Contractor shall be solely and completely responsible for the conditions of the job Site, including safety of all persons and property during performance of the Work. This requirement shall apply continuously and not be limited to normal working hours. Safety provisions shall conform to all applicable federal, state, and local laws, ordinances, and codes, and to the rules and regulations established by the California Division of Industrial Safety, and to other rules of law applicable to the Work.

(2) The services of the Construction Manager in conducting construction review of the Contractor's performance is not intended to include review of the adequacy of the Contractor's work methods, equipment, bracing or scaffolding or safety measures, in, on, or near the construction site, and shall not be construed as supervision of the actual construction nor make the Construction Manager or the City responsible for providing a safe place for the performance of work by the Contractor, Subcontractors, or suppliers; or for access, visits, use work, travel or occupancy by any person.

(3) The Contractor shall carefully instruct all personnel working in potentially hazardous work areas as to potential dangers and shall provide such necessary safety equipment and instruction as is necessary to prevent injury to personnel and damage to property. Special care shall be exercised relative to electrical work, work involving excavation and in sump pump work.

(4) All work and materials shall be in strict accordance with all applicable State, Federal and local laws, rules, regulations, and codes.

(5) Nothing in this Contract is to be construed to permit work not conforming to governing law. When Contract Documents differ from governing law, the Contractor shall furnish and install the higher standards called for without extra charge. All equipment furnished

shall be grounded and provided with guards and protection as required by safety codes. Where vapor-tight or explosion-proof electrical installation is required by law, this shall be provided.

(6) The Contractor shall submit a safety plan and/or narrative description to the Construction Manager prior to commencement of the Work. This safety plan and/or narrative description shall describe all first aid, safety clothing, etc. to be used at the Project Site.

(b) Shoring and Trench Safety Plan

(1) Attention is directed to Section 832 of the Civil Code of the State of California relating to lateral and subjacent support, and the Contractor shall comply with this law.

(2) In accordance with Section 6705 of the State Labor Code, the Contractor shall submit to the City specific plans to show details of provisions for worker protection from caving ground. Not less than thirty (30) days before beginning excavation for any trench or trenches five feet or more in depth required under this Contract, the Contractor shall furnish to the Construction Manager Working Drawings of its trench safety plan. The trench safety plan Working Drawings shall be detailed plans showing the design of shoring, bracing, sloping or other provisions to be made for worker protection from the hazard of caving ground. If such plan varies from the shoring system standards established by the Construction Safety Orders of the California Division of Industrial Safety or the Federal Safety and Health Regulations for Construction of the Occupational Safety and Health Administration, Department of Labor, the plan shall be prepared by a registered civil or structural Construction Manager. In no event shall the Contractor use a shoring, sloping, or protective system less effective than that required by said Construction Safety Orders, or less effective than that required by said Federal Safety Standards. Submission of this plan in no way relieves the Contractor from the requirement to maintain safety in all operations performed by the Contractor or its Subcontractors.

5.15. BLASTING

Except for exceptional circumstances, blasting shall be prohibited. Accordingly, Bids should be prepared on the basis that no blasting will be permitted. Should blasting be required and expressly approved by the City, the City will issue a Change Order for blasting work.

5.16. INTOXICATING LIQUORS AND NARCOTICS

The Contractor shall not sell, permit or suffer the introduction or use of intoxicating liquors or narcotics upon or about the Site.

5.17. PROTECTION OF PERSONS AND PROPERTY

(a) The Contractor shall take whatever precautions are necessary to prevent damage to all existing improvements, including above ground and underground utilities, trees, shrubbery that is not specifically shown to be removed, fences, signs, mailboxes, survey markers and monuments, buildings, structures, the City's property, adjacent property, and any other improvements or facilities within or adjacent to the work. If such improvements or property are injured or damaged by reason of the Contractor's operations, they shall be replaced or restored, at the Contractor's expense, to a condition at least as good as the condition they were in prior to the start of the Contractor's operations.

(b) The Contractor shall adopt all practical means to minimize interference to traffic and public inconvenience, discomfort or damage. The Contractor shall protect against injury to any pipes, conduits or other structures crossing the trenching or encountered in the Work and

shall be responsible for any injury done to such pipes or structures, or damage to property resulting therefrom. The Contractor shall support or replace any such structures without delay and without any additional compensation to the entire satisfaction of the Construction Manager. All obstructions to traffic shall be guarded by barriers illuminated at night. The Contractor shall be responsible for all damage to persons and property directly or indirectly caused by its operations and, under all circumstances, Contractor must comply with the laws and regulations of the State of California relative to safety of persons and property and the interruption of traffic and the convenience of the public within the respective jurisdictions.

(c) The Contractor is cautioned that it must replace all improvements in rights-of-way and within the public streets to a condition at least equal to what existed prior to the Contractor's entry onto the job.

(d) Type and time of construction required at any road subject to interference by the work will be determined by those authorities responsible for maintenance of said road. It shall be the responsibility of the Contractor to determine the nature and extent of all such requirements, including provision of temporary detours as required; however, the construction right-of-way obtained by the City at affected roadways will be adequate for provision of all required detours. As required at any road crossing, the Contractor shall provide all necessary flag persons, guardrails, barricades, signals, warning signs and lighting to provide for the safety of existing roads and detours. Immediately after the need for temporary detours ceases, or when directed, the Contractor shall remove such detours and perform all necessary cleanup work, including replacement of fences, and removal of pavement. Included shall be all necessary replacement of existing roadway appurtenances, grading work, soil stabilization and dust control measures, as required and directed.

(e) The Contractor shall examine all bridges, culverts, and other structures over which it will move its materials and equipment, and before using them, Contractor shall properly strengthen such structures where necessary. The Contractor shall be responsible for any and all injury or damage to such structures caused by reason of its operations.

5.18. RESPONSIBILITY FOR REPAIR OF FACILITIES

All public or private facilities, including but not limited to, gravel surfacing at existing canals, structures, telephone cables, roadways, curbs, gutters, parking lots, private drives, levees and embankments for creeks, ponds and reservoirs disturbed during construction of the work shall be repaired and/or replaced by the Contractor to match facilities existing prior to construction. In addition, the Contractor shall be responsible for any settlement damage to such facilities or adjoining areas for a period of one year after Acceptance of such required facilities.

5.19. CITY'S REPAIR

In the event the Contractor refuses or neglects to make good any loss or damage for which it is responsible under this Contract, the City may itself or by the employment of others, make good any such loss or damage, and the cost and expense of doing so, including any reasonable Construction Managering, legal and other consultant fees, and any costs of administrative and managerial services, shall be charged to the Contractor. Such costs and expenses may be deducted by the City from claims for payment made by the Contractor for work completed or remaining to be completed.

5.20. ANTITRUST CLAIM ASSIGNMENT

In entering into a public works contract or a subcontract to supply goods, services, or materials pursuant to this contract, the Contractor and all Subcontractors shall offer and agree

to assign to the City all rights, title, and interest in and to all causes of action it may have under Section 4 of the Clayton Act (15 U.S.C. Sec. 15) or under the Cartwright Act (Chapter 2 (commencing with Section 16700) of Part 2 of Division 7 of the Business and Professions Code), arising from purchases of goods, services or materials pursuant to the public works contract or subcontract. This assignment shall be made and become effective at the time the City tenders final payment to the Contractor, without further acknowledgement by the parties.

5.21. WAIVER OF RIGHT TO RESCIND FOR MATERIAL BREACH

The Contractor agrees that it can be adequately compensated by money damages for any breach of this Contract which may be committed by the City and hereby agrees that no default, act, or omission of the City or the Construction Manager, shall constitute a material breach of the Contract entitling the Contractor to cancel or rescind the provisions of this Contract or (unless the City shall so consent or direct in writing) to suspend or abandon performance of all or any part of the Work. The Contractor hereby waives any and all rights and remedies to which it might otherwise be or become entitled, save only its right to money damages.

5.22. CONTRACTOR'S LICENSE NOTICE

CONTRACTORS ARE REQUIRED BY LAW TO BE LICENSED AND REGULATED BY THE CONTRACTORS' STATE LICENSE BOARD. ANY QUESTIONS CONCERNING A CONTRACTOR MAY BE REFERRED TO:

REGISTRAR CONTRACTORS' STATE LICENSE BOARD
9821 BUSINESS PARK DRIVE
SACRAMENTO, CALIFORNIA 95827

MAILING ADDRESS:
P.O. BOX 26000
SACRAMENTO, CALIFORNIA 95826

5.23. HISTORICAL, SCIENTIFIC AND ARCHEOLOGICAL DISCOVERIES

All articles of historical or scientific value, including but not limited to coins, fossils, and articles of antiquity which may be uncovered by the Contractor during the progress of work, shall become City property. Such findings shall be reported immediately to the Construction Manager who will determine the method of removal, where necessary, and the final disposition thereof.

5.24. INSURANCE

Contractor shall procure and maintain for the duration of the contract insurance against claims for injuries to persons or damages to property, which may arise from or in connection with the performance of the Work hereunder by the Contractor, its agents, representatives, employees or Subcontractors. The cost of such insurance shall be included in the Contractor's bid.

(a) Neither the Contractor nor any Subcontractors shall commence any work until all required insurance has been obtained at their own expense. Such insurance must have the approval of the City as to limit, form, and amount, and shall be placed with insurers with a current A. M. Best's rating of no less than A-VII.

(b) Any insurance bearing on adequacy of performance shall be maintained after completion of the project for the full guarantee period.

(c) Prior to execution of the Contract, the Contractor shall furnish the City with original endorsements effecting coverage for all policies required by the Contract. The endorsements shall be signed by a person authorized by the insurer to bind coverage on its behalf. The endorsements are to be on forms provided or approved by the City. The City may require the Contractor or any Subcontractor to furnish complete certified copies of all insurance policies affecting the coverage required by the Contract.

(d) All of the Contractor's policies shall contain an endorsement providing that written notice shall be given to the City at least sixty (60) calendar days prior to termination, cancellation, or reduction of coverage in the policy.

(e) Any policy or policies of insurance that the Contractor elects to carry as insurance against loss or damage to its construction equipment and tools shall include a provision therein providing a waiver of the insurer's right to subrogation against the City and the Construction Manager.

(f) The requirements as to the types, limits, and the City's approval of insurance coverage to be maintained by the Contractor are not intended to and shall not in any manner limit or qualify the liabilities and obligations assumed by the Contractor under the Contract.

(g) In addition to any other remedy the City may have, if the Contractor or any of the Subcontractors fails to maintain the insurance coverage as required in this section, the City may obtain such insurance coverage as is not being maintained, in form and amount substantially the same as required herein, and the City may deduct the cost of such insurance from any amounts due or which may become due the Contractor under this Contract.

(h) The Contractor and all Subcontractors shall, at their expense, maintain in effect at all times during the performance of work under the Contract not less than the following coverage and limits of insurance, which shall be maintained with insurers and under forms of policy satisfactory to the City. The maintenance by the Contractor and all Subcontractors of the following coverage and limits of insurance is a material element of this Contract. The failure of the Contractor or any Subcontractor to maintain or renew coverage or to provide evidence of renewal may be treated by the City as a material breach of this contract.

(1) Workers' Compensation and Employer's Liability Insurance

(i) Workers' Compensation

The Contractor and all Subcontractors shall maintain insurance to protect the Contractor or Subcontractor from all claims under Workers' Compensation and Employer's Liability Acts, including Longshoremen's and Harbor Workers' Act. Such coverage shall be maintained, in type and amount, in strict compliance with all applicable State and Federal statutes and regulations. The Contractor shall execute a certificate in compliance with Labor Code section 1861, on the form provided in the Contract Documents.

(ii) Claims Against City

If an injury occurs to any employee of the Contractor or any of the Subcontractors for which the employee or its dependents, in the event of its death, may be entitled to compensation from the City under the provisions of the said Acts, or for which compensation is claimed from the City, there will be retained out of the sums due the Contractor

under this Contract, an amount sufficient to cover such compensation as fixed by said Acts, until such compensation is paid or it is determined that no compensation is due. If the City is required to pay such compensation, the amount so paid will be deducted and retained from such sums due, or to become due, the Contractor.

(2) Commercial General and Automobile Liability Insurance

The Contractor shall maintain in effect at all times during the performance of the work hereunder not less than the following coverage's and limits of Commercial General and Automobile Liability insurance:

(i) Form and Amount

The insurance shall include, but shall not be limited to, protection against claims arising from death, bodily injury, personal injury, or damage to property resulting from actions, failures to act, operations or equipment of the insured, or by its employees, agents or consultants, or by anyone directly or indirectly employed by the insured. The amount of insurance coverage shall not be less than \$2,000,000.00 per occurrence with an aggregate no less than two (2) times the required per occurrence limit applying to bodily injury, personal injury, and property damage, or any combination of the three. Any deductibles must be declared to and approved by the City. At the option of the City, either: the insurer shall reduce or eliminate such deductibles as respects the entity, its officers, officials, employees and volunteers; or the Contractor shall procure a bond guaranteeing payment of losses and related investigations, claim administration expenses, and defense expenses. The commercial general and automobile liability insurance coverage shall also include the following:

(ii) Additional Requirements

Provision or endorsement naming the City, the Construction Manager and its consultants, and each of their officers, employees, and agents, each as additional insured's with respect to any potential liability arising out of the performance of any work under the Contract, and providing that such insurance is primary insurance as respects the interest of the City and Construction Manager, and its consultants, and each of their officers, employees, and agents and that any other insurance, risk pool membership, or other liability protection maintained by the City or maintained by the Construction Manager is excess to the insurance required hereunder, and will not be called upon to contribute to any loss unless and until all limits available under the Contractor 's and Subcontractor's insurance policy/policies have been paid. The additional insured coverage under the Contractor's policy shall be "primary and non-contributory" and will not seek contribution from the City's insurance or self-insurance and shall be at least as broad as CG 20 01 04 13.

(iii) "Cross Liability" or "Severability of Interest" clause.

(iv) Broad Form Property Damage, Personal Injury, Contractual Liability, Protective Liability, and Completed Operations coverage's, and elimination of any exclusion regarding loss or damage to property caused by explosion or resulting from collapse of buildings or structures or damage to property underground, commonly referred to by insurers as the "XCU" hazards.

(v) Provision or endorsement stating that such insurance, subject to all of its other terms and conditions, applies to the liability assumed by the Contractor under the Contract, including, without limitation, that set forth in Section 4.02, Indemnity and Litigation Costs.

(vi) Provision or endorsement stating that any failure to comply with reporting or other provisions of the policies, including breaches of warranties, shall not affect coverage provided to the City, its officers, officials, employees, or volunteers.

(vii) The Contractor's insurance shall apply separately to each insured against whom claim is made or suit is brought, except with respect to the limits of the insurer's liability.

(3) Builder's Risk or Installation Floater "All-Risk" Insurance. Before commencement of the Work, the Contractor shall submit written evidence that it has obtained for the period of the Contract, Builder's Risk "All-Risk" Completed Value Insurance and/or Inland Marine "All-Risk" Installation Floater Insurance, as may be applicable, upon the entire project which is the subject of this Contract, including completed work and work in progress. The policy or policies of insurance shall name the Contractor, City, and Construction Manager as insured's as their respective interests may appear, and shall include an insurer's waiver of subrogation rights in favor of each. Such insurance may have a deductible clause, but the amount of the deductible shall be subject to the approval of the City, except that the deductible on earthquake coverage may be in accordance with the underwriter's requirements.

5.25. INDEMNITY AND LITIGATION COST

(a) Promptly upon execution of the Contract, the Contractor specifically obligates itself and hereby agrees to protect, hold free and harmless, defend and indemnify the City, the Construction Manager and its consultants, and each of their officers, employees and agents, from any and all liability, penalties, costs, losses, damages, expenses, causes of action, claims or judgments, including attorney's fees, which arise out of or are in any way connected with the Contractor's, or its Subcontractors' or suppliers', performance of work under this Contract or failure to comply with any of the obligations contained in the Contract. This indemnity shall imply no reciprocal right of the Contractor in any action on the contract pursuant to California Civil Code section 1717 or section 1717.5. To the fullest extent legally permissible, this indemnity, defense and hold harmless agreement by the Contractor shall apply to any and all acts or omissions, whether active or passive, on the part of the Contractor or its agents, employees, representatives, or Subcontractor's agents, employees and representatives, resulting in claim or liability, irrespective of whether or not any acts or omissions of the parties to be indemnified hereunder may also have been a contributing factor to the liability, except such loss or damage which was caused by the active negligence, the sole negligence, or the willful misconduct of the City. The Contractor's obligations under this Section shall apply to claims arising from the Contractor's mistake, error, or neglect in preparing its Bid for this project. The Contractor's obligations under this Section shall apply to claims arising from the Contractor's mistake, error, or neglect in preparing its Bid for this project.

(b) In any and all claims against the City, the Construction Manager and each of their consultants, officers, employees and agents by any employee of the Contractor, any Subcontractor, anyone directly or indirectly employed by any of them, or anyone for whose acts any of them may be liable, the indemnification obligation under this section shall not be limited in way by any limitation on the amount or type of damages, compensation or benefits payable by or for the Contractor or any Subcontractor under Workers' Compensation statutes, disability benefit statutes or other employee benefit statutes.

5.26. PROTECTION OF WORK

(a) The Contractor shall be responsible for the care of all the Work until its completion and final acceptance. The Contractor shall, at its own expense, replace damaged or

lost material and repair damaged parts of the Work or the same may be done at the Contractor's expense by the City and the Contractor and its sureties shall be liable therefor. The Contractor shall make its own provisions for properly storing and protecting all material and equipment against theft, injury, or damage from any and all causes. Damaged material and equipment shall not be used in the Work. The Contractor shall take all risks from floods and casualties except as provided by law, and shall make no charge for the restoration of such portions of the work as may be destroyed or damaged by flood or other casualties or because of danger from flood or other casualties or for delays from such causes. The Contractor may, however, be allowed a reasonable extension of time on account of such delays, subject to the conditions herein before specified. The Contractor shall not be responsible for the cost, in excess of 5% of the contracted amount, of repairing or restoring damage to the Work, if the damage was proximately caused by an earthquake in excess of a magnitude of 3.5 on the Richter Scale or by tidal wave' s; provided that the Work damaged was built in accordance with accepted and applicable building standards, and the plans and specifications of the City.

(b) Contractor shall effectively secure and protect adjacent property and structures, livestock, crops and other vegetation. If applicable, the Contractor shall open fences on or crossing the right-of-way and install temporary gates of sound construction thereon so as to prevent the escape of livestock. Adjacent fence posts shall be adequately braced to prevent the sagging or slackening of the wire. Before such fences are opened, the Contractor shall notify the owner or tenant of the property and, where practicable, the opening of the fence shall be in accordance with the wishes of said owner or tenant. The Contractor shall be responsible that no loss or inconvenience shall accrue to the owner or tenant by virtue of their fences having been opened or the gate not having been either shut or attended at all times. Where special types of fences are encountered, the Contractor shall install temporary gates made of similar materials and of suitable quality to serve the purposes of the original fences. In all cases where the Contractor removes fences to obtain workroom, the Contractor shall provide and install temporary fencing as required, and on completion of construction shall restore the original fence to the satisfaction of the Construction Manager. All costs of providing, maintaining and restoring gates and fencing shall be home by the Contractor. The Contractor shall provide and maintain all passageways, guard fences, lights and other facilities for protection required by public authority or local conditions.

(c) The Contractor shall use extreme care during construction to prevent damage from dust to crops and adjacent property. The Contractor, at its own expense, shall provide adequate dust control for the right-of-way and take other preventative measures as directed by the Construction Manager.

(d) The Contractor shall be responsible for all damage to any property resulting from trespass by the Contractor or its employees in the course of their employment, whether such trespass was committed with or without the consent or knowledge of the Contractor.

(e) The Contractor shall see that the Site is kept drained and free of all ground water and any other water, which may impede the progress or execution of the Work.

(f) The Contractor shall be responsible for any damage caused by drainage or water runoff from construction areas and from construction plant areas.

(g) In an emergency affecting the safety of life, the Work, or adjoining property, the Contractor, without special instruction or authorization from the Construction Manager, is hereby permitted to act at its discretion to prevent such threatened loss or injury, and the Contractor shall so act without appeal if so instructed or authorized. Any compensation claimed by the Contractor on account of emergency work shall be determined as specified In Section 2.07.

Should the Construction Manager deem an emergency condition to exist, the Contractor shall immediately do those things and take those steps ordered by the Construction Manager. The decision of the Construction Manager in this respect shall be final and conclusive. Any claims for compensation made by the Contractor on account of emergency work shall be determined as specified in Section 2.07.

(h) Except as provided by Government Code section 4215, the Contractor shall be responsible for the removal, relocation and protection of all public and private utilities, including irrigation facilities in the nature of utilities, located on the site of the construction project if and to the extent that the same are identified in the Contract Documents, and the Contractor shall not be entitled to any extension of time or claim for damages for extra compensation in connection therewith. If and to the extent that such utilities or facilities are not identified in the Contract Documents, as between the Contractor and the City, the City will be responsible for the cost of their removal, relocation or protection, as the case may be, but the Contractor shall perform any such work in conformance with applicable provisions of Sections 2.06 and 2.07, if so directed by the Construction Manager. In such situations the Contractor shall not be responsible for delay in completion of the project caused by the failure of the City or the owner of the utility to provide for such removal or relocation. If the Contractor, while performing the Contract, discovers utility or irrigation facilities not identified by the City in the Contract Documents, the Contractor shall immediately notify the Construction Manager in writing.

(i) Subject to the provisions of this section, where the Work to be performed under the Contract crosses or otherwise interferes with existing streams, watercourses, canals, farm ditches, pipelines, drainage channels, or water supplies, the Contractor shall provide for such watercourse or pipelines and shall perform such construction during the progress of the Work so that no damage will result to either public or private interests, and the Contractor shall be liable for all damage that may result from failure to so provide during the progress of the Work.

5.27. ACCIDENTS

(a) The Contractor shall provide and maintain, in accordance with Labor Code section 6708 and OSHA requirements, adequate emergency first-aid treatment for its employees and anyone else who may be injured in connection with the Work.

(b) The Contractor shall promptly report in writing to the Construction Manager all accidents whatsoever arising out of or in connection with, the performance of the Work, whether on or adjacent to the site, which caused death, personal injury, or property damage, giving full details and statements of witnesses. In addition, if death or serious injury or serious damage are caused, the accident shall be reported immediately by telephone or messenger to the City and the Construction Manager.

(c) If any claim is made by anyone against the Contractor or any Subcontractor on account of any accident, the Contractor shall promptly report the facts in writing to the Construction Manager, giving full details of the claim.

5.28. NO PERSONAL LIABILITY

Neither the City, the Construction Manager, nor any of their other officers, agents, or employees shall be personally responsible for any liability arising under the Contract, except such obligations as are specifically set forth herein.

SECTION 6

PROGRESS AND COMPLETION OF WORK

6.01. PROGRESS SCHEDULE

The Contractor shall submit within ten (10) days after execution of the Contract a detailed work schedule(s) which shall detail the actions of the Contractor and Subcontractors working at the Site. This schedule(s) shall both show the dates at which the Contractor will start and complete and conform to the completion time specified in the Contract. The controlling operation, defined as the least float path, if any, shall be identified.

The Contractor shall review, revise and resubmit the progress schedule at least once a month to reflect progress. In any event, Contractor shall submit, at any time during the contract period, a current schedule to the Construction Manager at the Construction Manager's request.

No progress payments will be made for any work performed until a satisfactory schedule has been submitted and approved by the Construction Manager. An updated schedule shall be required from the Contractor if the project falls ten (10) working days behind schedule.

If the Work falls behind the accepted schedule, the Contractor shall promptly take whatever actions are necessary to put the project back on schedule. For delays or portions of delays for which the Contractor is responsible, no payment will be made or time extension allowed for increase in work force, equipment, and working hours needed to put the project on schedule.

6.02. COMMENCEMENT AND PROGRESS OF THE WORK AND TIME OF COMPLETION

(a) Commencement

The Contractor shall begin the Work after receiving a Notice to Proceed within the period of time set forth in the Contract Provisions. Thereafter, Contractor shall diligently prosecute the Work to completion as specified in the Contract Documents. The Construction Manager shall have the right to specify the locations where Contractor shall start and proceed with the Work.

A preconstruction conference will be convened after the Contractor has delivered the necessary bonds, insurance certificates and signed agreement in proper form as required in the Request for Qualification and Proposal, Bid proposal and general conditions of these specifications. Prior to any work, the Contractor shall provide the Construction Manager with a list of key personnel assigned to the project and the telephone numbers where they may be reached at any time. The list shall be made available in sufficient copies and presented at the preconstruction conference.

Notwithstanding any other provisions of the Contract, the City shall not be obligated to accept or pay for any work furnished by the Contractor prior to the issuance of the Notice to Proceed whether or not the City has knowledge of the furnishing of such work. The Contractor shall not commence with work on this project until its Contract bonds and evidence of insurance comply with all Contract requirements and a Notice to Proceed has been issued.

The Contractor shall notify the Construction Manager in writing two (2) working days (48 hours) prior to commencement of work on the Project or scheduling work for a Saturday, Sunday, or City Holiday. Failure to provide said notification will void the City's obligation to

provide inspection. Any work done in the absence of the City's Inspector shall be subject to rejection.

(b) Completion

All work under this Contract shall be completed within the period of time set forth in the Contract Provisions. The Contract shall be deemed completed when the Construction Manager has certified the completion of the Project as provided in Section 9.07 of these General Conditions.

6.03. SUSPENSION OF WORK

(a) The Construction Manager may at any time, by notice in writing to the Contractor, suspend any part of the Work for such period of time as may be necessary to prevent improper execution of the Work on the project by the Contractor, its Subcontractors or agents, and the Contractor shall have no claim for damages or additional compensation on account of any such suspension.

(b) The City may at any time suspend any part or all of the Work upon ten (10) days written notice to the Contractor, who shall thereupon discontinue all work suspended except for all operations to prevent loss or damage to work already executed as may be directed by the Construction Manager. Work shall be resumed by the Contractor after such suspension on written notice from the City.

(c) In the event of any suspension of the Work in whole or in part under subsection (B) above, the Contractor shall be entitled to an extension of time wherein to complete the Work to the extent of the delay caused to the Contractor thereby.

(d) In the event the entire work shall be suspended by order of the City, as herein above provided, and shall remain so suspended for a period of sixty (60) consecutive days, through no fault of the Contractor, and notice to resume the Work shall not have been served on the Contractor as herein above provided, Contractor may, at its option, by written notice to the City, terminate the Contract in the same manner as if the termination had been initiated by the City, and the City shall have no claim for damages because of such termination of the Contract.

6.04. DELAY IN THE WORK – TIME EXTENSIONS

The Contractor shall at all times employ such force, plant, materials, and tools as will be sufficient, in the opinion of the Construction Manager, to prosecute the Work at not less than the rates fixed under the terms of the Contract and to complete the Work thereof within the time limits fixed therein. If the Contractor refuses or fails to prosecute the Work, or any separable part thereof, with such diligence as will ensure the completion within the time specified in the Contract, or any extension thereof, or fails to complete said work within such time, the City may exercise the termination provisions set forth in Section 6.05, below.

(a) Excusable Delays. Excusable delays shall be delays in the controlling operation of the Contractor's work due to strikes, lockouts by others, fire, unusual delay in transportation, unavoidable casualties, adverse weather conditions which could not have been reasonably anticipated, or any other act(s) of God beyond the Contractor's control, or by delay authorized by the City, or by any cause which the City shall decide to justify the delay. Except as provided in Section 6.04(f), below, in the event of an excusable delay, the time of completion shall be extended for such reasonable time as the City may decide. The Contractor's right to an extension of time for an excusable delay is expressly subject to Contractor's giving written notice of such claim within ten (10) days following the date the Contractor knew or should have

known of the delay. Failure to give such notice shall be construed as a waiver of such right. It is understood and agreed that extensions of time shall be the Contractor's sole and exclusive remedy for excusable delays.

(b) Compensable delays. Compensable delays shall be delays in the controlling operating of the Contractor's work due to acts or neglect of the City, its employees or those under it by contract or otherwise, or by changes ordered in the work. In the event of a compensable delay, the time of completion shall be extended for such reasonable time as the City may decide. In addition, the Contractor may recover its direct costs as provided in Section 6.05. The Contractor's remedies for compensable delays are expressly subject to Contractor's giving ten (10) days written notice of such claim from the date the Contractor knew or should have known of the delay. It is understood and agreed that the Contractor's sole and exclusive remedies for compensable delays shall be an extension of the time and recovery of its direct costs as compensable hereunder, but only in accordance with the provisions of the Contract Documents.

(c) Contractor and City understand and agree that the Contract time for the completion of this project is a very important part of the contract. Extensions of time will only be granted as provided above when events actually cause the Contractor to be delayed in the performance of that schedule activity which is the controlling operation as of the time of the delay. When acts or omissions occur which could cause delay, Contractor will take all reasonable means in order to be able to continue to work as scheduled without any delay, or as short a delay as possible. Additionally, if inclement weather causes accumulation of standing water on the work site or other conditions which might cause delay, Contractor shall take all measures reasonably necessary to permit work to continue as quickly as possible.

(d) If adverse weather conditions are the basis for a claim for additional time, such claim shall be documented by date substantiating that weather conditions were abnormal for the period of time and could not have been reasonably anticipated, and that weather conditions had an adverse effect on the scheduled construction. Adverse weather conditions shall be considered only as those conditions that exceed the average annual number of rain days and rain quantities as established by the Annual Local Climatological Summary and NOAA National Technical Memorandum NWS WR-65 (Revised) as published by the United States Government, National Weather Service, National Climate Center, Asheville, North Carolina.

(e) The Construction Manager shall be responsible for determining when adverse weather conditions result in non-workable days. It shall be the Contractor's duty to stay informed of such determinations by the Construction Manager. The Contractor may object to such adverse weather determinations by filing with the Construction Manager a written notice of objection. The notice of objection shall state the basis of the objection and provide supporting documentation, which substantiates that weather conditions were abnormal for the period of time and could not have been reasonably anticipated, and that weather conditions had an adverse effect on the scheduled construction. All such notices of objection shall be filed within three (3) days of the day in dispute. It is hereby agreed that the Contractor's failure to submit a written notice of objection within three (3) days of the Construction Manager's adverse weather determination shall constitute a waiver by the Contractor of all its rights to further protest, judicial or otherwise.

(f) The Construction Manager will, within a reasonable period of time, issue a ruling on the Contractor's notice of objection. All such rulings by the Construction Manager shall be final, unless the Contractor files a written protest within fifteen (15) days of the Construction Manager's ruling. This protest shall clearly state the basis of the dispute. Such protest will be forwarded promptly to the City, which will issue a decision on each such protest. The City

decision will be final. Pending the City decision, the Contractor shall proceed with its work in accordance with the Construction Manager's ruling and/or instructions. It is hereby agreed that the Contractor's failure to file a protest within fifteen days (15) of the Construction Manager's ruling shall constitute a waiver by the Contractor of all its rights to further protest, judicial or otherwise.

(g) The number of days that are anticipated to be non-workable due to adverse weather conditions shall be as set forth in Section 4.0 of the Special Conditions. Days deemed non-workable by the Construction Manager in excess of such anticipated number shall be considered excusable delays.

(h) Unexcused delays shall be delays in the Contractor's work due to acts or neglect of the Contractor, its employees, Subcontractors or those under it by contract or otherwise. In the event of an unexcused delay, the Contractor expressly agrees that it shall not be entitled to either an extension of time or recovery of its costs.

(i) A request for an extension of time, or the granting of an extension of time, shall not constitute a basis for any claim against the City for additional compensation or damages unless caused by the City or another Contractor employed by the City.

6.05. DAMAGES FOR DELAY

In the event of compensable delay, the City shall only be liable for idle equipment, idle workers and the necessary costs of transporting equipment. The City shall be liable to the extent that the compensable delay is concurrent with excusable delays or Contractor caused delays to the controlling operation. The allowable costs shall be as for force account work under Section 2.04 with the following exceptions:

(a) The Delay Factor in the Labor Surcharge and Equipment Rental Rules applies to each equipment rental rate;

(b) The daily number of payable hours shall equal the normal working hours during the delay, not to exceed eight (8) hours per day; and

(c) No markups will be added.

6.06. TERMINATION FOR CONVENIENCE

If at any time before completion of the Work, the City determines that it is either impossible or against the interests of the City to complete the Work, or if the Work is stopped by an injunction of a court of competent jurisdiction or by order of any competent authority, the City may, upon ten (10) days written notice to the Contractor, discontinue the Work and terminate the Contract. Upon service of such notice of termination, the Contractor shall discontinue the Work in such manner, sequence, and at such times as described below. The Contractor shall have no claim for damages for such discontinuance or termination, nor any claim for anticipated profits on the Work thus dispensed with, nor any other actually performed up to the time of discontinuance, including any Extra Work ordered by the Construction Manager to be done, nor for any claim for liquidated damages.

Termination of the Contract for convenience and the total compensation payable to the Contractor in the event of termination shall be governed by the following:

(a) The Construction Manager will issue the Contractor a written notice signed by the Construction Manager, specifying that the Contract is to be terminated. Upon receipt of said

written notice and, except as otherwise directed in writing by the Construction Manager, the Contractor shall:

- (1) Stop all Work under the Contract except that specifically directed to be completed prior to Acceptance.
- (2) Perform Work the Construction Manager deems necessary to secure the project for termination.
- (3) Remove equipment from the site of the Work.
- (4) Take such action as is necessary to protect materials from damage.
- (5) Notify all Subcontractors and suppliers that the Contract is being terminated and that their contracts or orders are not to be further performed unless otherwise authorized in writing by the Construction Manager.
- (6) Provide the Construction Manager with an inventory list of all material previously produced, purchased or ordered from suppliers for use in the Work and not yet used in the Work, including its storage location, and such other information as the Construction Manager may request.
- (7) Dispose of material not yet used in the Work as directed by the Construction Manager.

It shall be the Contractor's responsibility to provide the City with good title to all materials purchased by the City hereunder, including material for which partial payment has been made and with bills of sale or other documents of title for such materials.

- (8) Subject to the prior written approval of the Construction Manager, settle all outstanding liabilities and all claims arising out of subcontracts or orders for material terminated hereunder. To the extent directed by the Construction Manager, the Contractor shall assign to the City all the right, title and interest of the Contractor under subcontracts or orders for materials terminated hereunder.
- (9) Furnish the Construction Manager with the documentation required to be furnished by the Contractor under the provisions of the Contract including, on projects as to which Federal funds are involved, all documentation required under the Federal requirements included in the Contract.
- (10) Take such other actions as the Construction Manager may direct.

(b) Termination of the Contract shall not relieve the Contractor of responsibility for damage to materials except as follows:

- (1) The Contractor's responsibility for damage to materials for which partial payment has been made and for materials furnished by the City for use in the Work and unused shall terminate when the Construction Manager certifies that such materials have been stored in the manner and at the locations he or she has directed.

- (2) The Contractor's responsibility for damage to materials purchased by the City subsequent to the issuance of the notice that the Contract is to be terminated shall terminate when title and delivery of such materials has been taken by the City.

(3) When the Construction Manager determines that the Contractor has completed the Work under the Contract directed to be completed prior to termination and such other Work as may have been ordered to secure the project for termination, he or she will recommend that the Construction Manager formally accept the Contract, and immediately upon and after such Acceptance by the Construction Manager, the Contractor will not be required to perform any further Work thereon and shall be relieved of his or her Contractual responsibilities for injury to persons or damage to property which occurs after the formal Acceptance of the project by the Construction Manager.

(c) The total compensation to be paid to the Contractor shall be determined by the Construction Manager on the basis of the following:

(1) The reasonable cost to the Contractor, without profit, for all Work performed under the Contract, including mobilization, demobilization and Work done to secure the project for termination. Reasonable cost will include a reasonable allowance for project Overhead and general administrative Overhead not to exceed a total of seven (7%) percent of Direct Costs of such Work.

(2) A reasonable allowance for profit on the cost of the Work performed as determined under Section 2.04(a) above, provided the Contractor establishes to the satisfaction of the Construction Manager that it is reasonably probable that he or she would have made a profit had the Contract been completed and provided further, that the profit allowed shall in no event exceed four (4%) percent of said cost.

(3) The reasonable cost to the Contractor of handling material returned to the vendor, delivered to the City or otherwise disposed of as directed by the Construction Manager.

(4) A reasonable allowance for the Contractor's administrative costs in determining the amount payable due to termination of the Contract.

All records of the Contractor and the Subcontractors, necessary to determine compensation in accordance with this section shall be open to inspection or audit by representatives of the City at all times after issuance of the notice that the Contract is to be terminated and for a period of three (3) years, and such records shall be retained for that period.

After Termination of the Work by the Construction Manager, the Construction Manager may make payments on the basis of interim estimates pending issuance of the Final Statement, when in his or her opinion the amount thus paid, together with all amounts previously paid or allowed, will not result in total compensation in excess of that to which the Contractor will be entitled.

All payments, including payment upon the Final Statement, shall be subject to deduction for prior payments and amounts, if any, to be kept or retained under the provisions of the Contract.

(d) The provisions of this section shall be included in all subcontracts.

6.07. TERMINATION FOR DEFAULT

(a) In the event of any default by the Contractor as described below, the City may, after giving ten (10) days' written notice to the Contractor, terminate the Contractor's right to proceed with the Work or any part of the Work in the City's sole discretion. Events of default include:

(1) Failure or refusal to prosecute the Work, or any separable part thereof, with such diligence as will ensure the completion within the time specified in the Contract, or any extension thereof, or failure to complete said work within such time.

(2) Filing of bankruptcy by the Contractor, or the making of a general assignment for the benefit of its creditors, or appointment of a receiver on account of Contractor's insolvency without discharge of the receiver within ten (10) days after its appointment.

(3) Failure to make prompt payments to Subcontractors or suppliers.

(4) Persistent disregard of laws, ordinances, or the instructions of the Construction Manager, or other substantial violation of any provision of the Contract.

(b) In the event the right of the Contractor to proceed with the Work, or any portion thereof, has been terminated because of the default of the Contractor and the Contractor has been given ten (10) days' notice to cure such fault and has not done so, the City may take over the Work and prosecute the same to completion by contract or any other method the City deems expedient, and may take possession of and utilize in completing the Work such materials, appliances, equipment and plant as may be on the site of the Work and necessary therefore. In such event, the Contractor and its sureties shall be liable for all damages including costs of managerial and administrative services, Construction Managerring, legal and other consultant fees, and liquidated damages sustained or incurred by the City.

(c) Upon termination, the Contractor shall not be entitled to receive any further payment until the Work is finished. If upon completion of the Work the total cost to the City, including Construction Managerring, legal and other consultant fees, costs of managerial and administrative services, construction costs, and liquidated damages shall be less than the amount which would have been paid if the Work had been completed by the Contractor in accordance with the terms of the Contract, then the difference shall be paid to the Contractor in the same manner as the final payment under the Contract. If the total cost incurred by the City on account of termination of the Contract and subsequent completion of the Work by the City by whatever method the City may deem expedient shall exceed said amount which the Contractor would otherwise have been paid, the Contractor and its sureties shall be liable to the City for the full amount of such excess expense.

(d) The rights and remedies of the City provided in this section are in addition to any of the rights and remedies provided by the law or under this Contract.

6.08. FAILURE TO TIMELY COMPLETE THE WORK – LIQUIDATED DAMAGES

(a) Liquidated Damages

(1) It is agreed by the parties to this Contract that time is of the essence. In the event all the Work is not completed before or upon the expiration of the time limit as set in the Bid, Contract and/or Progress Schedule, or within any time extensions that may have been granted, damage will be sustained by the City; and that it may be impracticable to determine the actual amount of damage by reason of such delay. Accordingly, it is agreed that the Contractor shall pay to the City as damages the amount set forth for each and every day's delay in finishing the Work in excess of the number of days specified. Liquidated damages shall be paid at a rate of one thousand dollars (\$1,000.00) per day unless otherwise stated in the Contract Documents. The parties expressly agree that the liquidated damage clause found in the Contract Documents is reasonable under the circumstances existing at the time the Contract was made. The City

shall have the right to deduct the amount of liquidated damages from any money due or to become due the Contractor.

(2) In addition, the City shall have the right to charge to the Contractor and to deduct from the final or progress payments for the Work the actual cost to the City of legal, Construction Managing, inspection, superintendence, and other expenses, which are directly chargeable to the Contract and which accrue during the period of such delay, except that the cost of final inspection and preparation of the final estimate shall not be included in the charges.

(b) Exclusions

Notwithstanding the provisions of Section 2.06(a), the Contractor shall not be liable for liquidated damages or delays caused by the removal or relocation of utilities when such removal or relocation is the responsibility of the City or the owner of the utility under Government Code section 4215.

6.09. CLEAN-UP

During the progress of the Work, the Contractor shall maintain the Site and related structures and equipment in a clean, orderly condition and free from unsightly accumulation of rubbish. All waste materials shall be removed daily from the Site and disposed of by the Contractor by any proper means at its own expense unless designated otherwise on the plans. No waste materials shall be placed in the public street right-of-way. Unless otherwise specified, all existing piping, materials and/or equipment removed pursuant to this Contract shall become the Contractor's property.

Upon completion of the Work and before the final estimate is submitted, the Contractor shall, at its own cost and expense, remove from the vicinity of the Work all plants, buildings, rubbish, unused work materials, concrete forms, and temporary bridging and other like materials, belonging to the Contractor or used under the Contractor's direction during the construction, and in the event of the Contractor's failure to do so, the same may be removed by the City after ten (10) calendar days' notice to the Contractor. Such removal shall be at the expense of the Contractor.

The Contractor shall use care in the removal of materials and equipment so as not to cause damage to existing facilities and structures. Contractor shall assume liability for all such damage. Where the construction has crossed yards or driveways, restoration shall be by the Contractor to the complete satisfaction of the Construction Manager, at the Contractor's expense.

The Contractor shall make its own arrangements for the disposal of waste materials. If the Contractor elects to dispose of such materials on private property, Contractor shall obtain written permission from all property owners involved.

SECTION 7

MEASUREMENT AND PAYMENT

7.01. MEASUREMENT OF QUANTITIES

(a) Where the Contract provides for payment on a lump sum price basis, no measurement of quantity will be made. Where the Contract provides for payment on a unit price basis, the quantities of work performed will be computed by the Construction Manager on the basis of measurements taken by the Construction Manager, and these measurements shall be final and conclusive.

(b) All quantities of work computed under the Contract shall be based upon measurements by the Construction Manager according to United States Measurements and Weights.

(c) Methods of measurement are specified herein and in the Technical Specifications.

(d) Mobilization shall be measured and payment issued according to Section 11 of the State Standard Specifications.

7.02. SCOPE OF PAYMENT

(a) The Contractor shall accept the compensation provided in the Contract as full payment for furnishing all labor, materials, tools, equipment, and incidentals necessary to the completed work and for performing all work contemplated and embraced under the Contract; also for loss or damage arising from the nature of the work, or from the action of the elements, or from any unforeseen difficulties which may be encountered during the prosecution of the Work until the Acceptance by the City and for all risks of every description connected with the prosecution of the Work, also for all expenses incurred in consequence of the suspension or discontinuance of the work as provided in the Contract; and for completing the Work according to the Specifications and Plans. Neither the payment of any estimate nor of any retained percentage shall relieve the Contractor of any obligation to make good any defective work or material.

(b) No compensation will be made in any case for loss of anticipated profits. Increased or decreased work involving supplemental agreements will be paid for as provided in such agreements.

(c) The Work includes the preparatory work and operations needed for mobilization and demobilization of the Project. The Work, however, does not include establishing the Construction Manager's field facility(s) of utility work and connections needed for these facilities.

7.03. PROGRESS ESTIMATE

For each calendar month of Contract work, the Construction Manager will prepare a progress estimate of all work performed under the Contract. Within the first ten (10) days of each succeeding calendar month, the Construction Manager will prepare in writing an estimate which in the Construction Manager's opinion is a fair approximation of the value of all work done under the Contract, including any amounts due the Contractor for Extra Work and Change Orders. In arriving at the value of the Work done, the Construction Manager will give consideration to the value of labor and materials which have been incorporated into the

permanent work by the Contractor during the preceding month. Consideration will not be given to preparatory work done or for materials or equipment on hand.

In order to assist the Construction Manager, the Contractor shall furnish the Construction Manager with copies of invoices for all such items delivered to the job site.

7.04. PROGRESS PAYMENTS

(a) The City will pay the Contractor ninety-five percent (95%) of the amount of each progress estimate within thirty (30) days after receipt of an undisputed and properly submitted progress estimate from the Contractor, unless the City has made a finding prebid pursuant to Public Contract Code section 7201(b)(4) justifying a larger retention. If the City fails to pay an undisputed progress estimate within the allotted thirty (30) days, the City shall pay interest to the Contractor equivalent to the legal rate set forth in subdivision (A) of section 685.010 of the Code of Civil Procedure. Five percent (5%) of the amount of each estimate shall be retained by the City until final completion and Acceptance of all work under the Contract.

(b) Upon receipt of a payment request, the City shall act in accordance with both of the following:

(1) Each payment request shall be reviewed by the City as soon as practicable after receipt for the purpose of determining that the progress estimate is a proper payment request.

(2) Any payment request determined not to be a proper payment request suitable for payment shall be returned to the Contractor as soon as practicable, but not later than seven (7) days, after receipt. A request returned pursuant to this section shall be accompanied by a document setting forth in writing the reasons why the payment request is not proper.

(c) The number of days available to the City to make a payment without incurring interest pursuant to this section shall be reduced by the number of days by which the City exceeds the seven-day return requirement set forth in paragraph (2) of subdivision (b).

(d) The Contractor may, in accordance with the provisions of Public Contracts Code section 22300, substitute securities for any monies which the City may withhold to insure performance under the Contract.

(e) When, in the judgment of the Construction Manager, the Work is not proceeding in accordance with the provisions of the Contract, or when in the Construction Manager's judgment the total amount of the Work done since the last estimate amounts to less than one thousand dollars (\$1,000.00), no pay estimate will be prepared and no progress payment will be made.

(f) No progress estimate or payment shall be considered to be an approval or Acceptance of any work, materials or equipment. Estimated amounts and values of work done and materials and equipment furnished will be conformed with actual amounts and values as they become available in subsequent progress estimates, progress payments and the final estimate and payment. All estimates and payments will be subject to correction in subsequent progress estimates and payments and the final estimate and payment.

(g) It is mutually agreed between the parties to the Contract that no payments made under the Contract, including progress payments and the final payment shall be evidence of the

performance of the Contract, either wholly or in part, and no payment shall construed to be an Acceptance of any defective or incomplete work or improper materials.

7.05. PROMPT PROGRESS PAYMENT TO SUBCONTRACTORS

A prime Contractor or Subcontractor shall pay any Subcontractor not later than seven (7) days of receipt of each progress payment in accordance with the provisions in Section 7108.5 of the California Business and Professions Code concerning prompt payment to Subcontractors. The seven (7) days is applicable unless a longer period is agreed to in writing. Any delay or postponement of payment over 30 days may take place only for good cause and with the City's prior written approval. Any violation of Section 7108.5 shall subject the violating Contractor or Subcontractor to the penalties, sanctions and other remedies of that section. This requirement shall not be construed to limit or impair any contractual, administrative, or judicial remedies otherwise available to the Contractor or Subcontractor in the event of a dispute involving late payment or nonpayment by the prime Contractor, deficient subcontract performance, or noncompliance by a Subcontractor. This provision applies to both DBE and non-DBE Subcontractors.

7.06. LIENS AND STOP NOTICES

The Contractor agrees to keep the Work, the site of the Work and all monies held by the City free and clear of all liens and stop notices related to labor and materials furnished in connection with the Work, if permitted by law. Furthermore, the Contractor waives any right it may have to file any type of lien or stop notice in connection with the Work. Notwithstanding anything to the contrary contained in the Contract Documents, if any such lien or stop notice is filed or there is evidence to believe that lien or stop notice may be filed at any time during the progress of the Work or within the duration of this Contract, the City may refuse to make any payment otherwise due the Contractor or may withhold any payment due the Contractor a sum sufficient in the opinion of the City to pay all obligations and expenses necessary to satisfy such lien or stop notice. The City may withhold such payment unless or until the Contractor, within ten days after demand therefor by the City, shall furnish satisfactory evidence that the indebtedness and any lien or stop notice in respect thereof has been satisfied, discharged and released of record, or that the Contractor has legally caused such lien or stop notice to be released of record pending the resolution of any dispute between the Contractor and any person or persons filing such lien or stop notice. If the Contractor shall fail to furnish such satisfactory evidence within ten days of the demand therefor, the City may discharge such indebtedness and deduct the amount thereof, together with any and all losses, costs and damages suffered or incurred by the City from any sum payable to the Contractor under the Contract Documents, including but not limited to final payment and retained percentage. This section shall be specifically included in all Subcontracts and purchase orders entered into by the Contractor.

7.07. FINAL ACCEPTANCE AND DATE OF COMPLETION

Whenever the Contractor shall deem all Work under this Contract to have been completed in accordance therewith, the Contractor shall so notify the Construction Manager in writing, and the Construction Manager shall promptly ascertain whether the Work has been satisfactorily completed and, if not, shall advise the Contractor in detail and in writing of any additional work required. When all the provisions of the Contract have been fully complied with, to the satisfaction of the Construction Manager, the Construction Manager shall proceed with all reasonable diligence to determine accurately the total value of all Work performed by the Contractor at the prices set forth in the Contract or fixed by Change Orders, and the total value of all extra work, all in accordance with the Contract. The Construction Manager will then certify to said final estimate and to the completion of the Work, and will file copies thereof with the City

and the Contractor, and shall cause of Notice of Completion to be filed with the Yuba County Clerk-Recorder . The date of completion shall be the date of filing of the Notice of Completion. All guarantees, warranties, and securities securing said guarantees and warranties, shall commence on said date.

7.08. RIGHT TO WITHHOLD PAYMENTS

(a) In addition to all other rights and remedies of the City hereunder and by virtue of the law, the City may withhold or nullify the whole or any part of any partial or final payment to such extent as may reasonably be necessary to protect the City from loss on account of:

- (1) Defective work not remedied, irrespective of when any such work be found to be defective;
- (2) Claims or liens filed or reasonable evidence indicating probable filing of claims or liens including, but not limited to claims under Sections 1775, 1776, or 1777.7 of the Labor Code;
- (3) Failure of the Contractor to make payments properly for labor, materials, equipment, or other facilities, or to Subcontractors and/or suppliers;
- (4) A reasonable doubt that the Work can be completed for the balance then unearned;
- (5) A reasonable doubt that the Contractor will complete the Work within the agreed time limits;
- (6) Costs to the City resulting from failure of the Contractor to complete the Work within the proper time; or
- (7) Damage to work or property.

(b) Whenever the City shall, in accordance herewith, withhold any monies otherwise due the Contractor, written notice of the amount withheld and the reasons therefor will be given the Contractor. After the Contractor has corrected the enumerated deficiencies, the City will promptly pay to the Contractor the amount so withheld. When monies are withheld to protect the City against claims or liens of mechanics, material men, Subcontractors, etc., the City may at its discretion permit the Contractor to deliver a surety bond in terms and amount satisfactory to the City, indemnifying the City against any loss or expense, and upon Acceptance thereof by the City, the City shall release to the Contractor monies so withheld.

7.09. FINAL PAYMENT

Within ten (10) days after the date of completion, the City will file in the Office of the County Recorder, a Notice of Completion of the Work herein agreed to be done by the Contractor. Within sixty (60) days of completion defined in Public Contract Code section 7107, the difference between said final estimate and all payments theretofore made to the Contractor shall be due and payable to the Contractor, subject to any requirements concerning the furnishings of a maintenance bond, and excepting only such sum or sums as may be withheld or deducted in accordance with the provisions of this Contract. All prior certifications upon which partial Payments may have been made, being merely estimates, shall be subject to correction in the final certificate.

7.10. FINAL RELEASE

Final payment to the Contractor in accordance with the final estimate is contingent upon the Contractor furnishing the City with a signed written release of all claims against the City arising by virtue of the Contract. Disputed Contract claims in stated amounts may be specifically excluded by the Contractor from the operation of the release. The release shall be in substantially the form specified in California Civil Code section 8138.

**PART 4 SUPPLEMENTAL CONDITIONS
(SPECIAL PROVISIONS)**

SUPPLEMENTAL CONDITIONS (SPECIAL PROVISIONS)

Except as modified by these Supplemental Conditions, the work shall be performed in accordance with Part 3 General Conditions. The numbering of these Supplemental Conditions coincides to the numbering in the General Conditions. The existence of a section in these Supplemental Conditions means that a corresponding section in the General Conditions is modified in some respect. Under these contract documents, Supplemental Conditions and Special Provisions have the same meaning.

The following Supplemental Conditions...

City Standard Details may be purchased from City Hall at:

526 C Street
Marysville, California 95901
or by calling (530) 749-3902 for purchase by mail.

PART 5 TECHNICAL SPECIFICATIONS

Contractor shall provide submittals (shop drawings) for all materials to be installed or used on the project. The work shall be performed in accordance with all local, state, and federal laws and regulations.

Scope of Work

WINDOWS: Remove and Replace all existing windows at City Hall and The Police Department with Retrofit Window Units. Existing External frames remain in place, protect surrounding wall finishes during installation. New retrofit windows shall be Milgard Tuscan Series V400, or city approved equal, meeting minimum specifications for glass, energy performance and finishes. The work includes field verification of all dimensions and quantities, coordination with the City Hall representative to schedule installation around City and Police Operations, and proper installation of safety glazing for all windows below the first floor. Contractor to provide two Special roof access windows located on the North and South Side that require casement unit with Full 90 degree swing. (See Attachment #1).

FLASHING: Provide New Metal Sill Cap over existing wood sill at exterior. Pre-finish metal cap prior to installation, ensure quality installation free of damage to existing elements and comply with all applicable code and city requirements. Provide Butyl Rubber seal at Sill Cap to wall and at bottom to concrete, install prior to setting new window unit. (See Attachment #1)

GENERAL NOTES

1. THE CITY HALL WINDOW REPLACEMENT—RETROFIT PROJECT CONSISTS OF THE REMOVAL OF THE WINDOW UNIT (FIXED OR OPERABLE PORTION) WHILE LEAVING IN PLACE THE EXTERNAL WINDOW FRAME. CARE SHALL BE TAKEN TO PROTECT THE WINDOW FRAME AND SURROUNDING EXTERIOR WALL AND SILL DURING THE REMOVAL AND NEW INSTALLATION PROCESS. INSIDE ELEMENTS SUCH AS SILL, CASINGS, TRIM, ETC. SHALL BE PROTECTED DURING THE REMOVAL AND NEW INSTALLATION PROCESS
2. WINDOW CONTRACTOR SHALL FIELD VERIFY ALL WINDOW OPENINGS AND ALL EXISTING FRAME DIMENSIONS REQUIRED FOR THE CONSTRUCTION OF THE NEW WINDOW UNIT PRIOR TO ORDERING NEW WINDOW UNIT
3. WINDOW CONTRACTOR SHALL FIELD VERIFY ALL VERTICAL AND HORIZONTAL MULLION PLACEMENT WITH CITY REPRESENTATIVE PRIOR TO ORDERING NEW WINDOW UNIT. THIS IS TO ASSURE REPLACEMENT WINDOWS MATCH THE CITY'S INTENT AND VISUAL APPEARANCE FOR THE HISTORIC CITY HALL BUILDING
4. ANY EXISTING DAMAGE TO THE EXTERIOR OR INTERIOR ELEMENTS OBSERVED PRIOR TO START OF THE RETROFIT SHALL IMMEDIATELY BE REPORTED THE CITY HALL REPRESENTATIVE
5. ANY DAMAGE TO THE EXTERIOR OR INTERIOR ELEMENTS CAUSED BY THE CONTRACTOR DURING THE RETROFIT PROJECT SHALL IMMEDIATELY BE REPORTED THE CITY HALL REPRESENTATIVE
6. ANY ISSUES ARISING FROM THE PROPOSED OVERALL RETROFIT OF ANY WINDOW UNIT SHALL BE IMMEDIATELY REPORTED THE CITY HALL REPRESENTATIVE
7. MILGARD TUSCANY SERIES V400 WINDOWS OR "CITY APPROVED EQUAL" MEETING THE MINIMUM SPECIFICATIONS MAY BE ACCEPTABLE AS THE RETROFIT WINDOW UNIT FOR THE PROJECT. SPECIFICATIONS FOR THE PROPOSED SUBSTITUTION SHALL BE SUBMITTED TO THE CITY HALL REPRESENTATIVE
 GLASS: 1/8" SunCoatMAX (LOW-E) OVER 1/8" CLEAR WITH BLACK EdgeGard SPACER
 U-FACTOR: 0.26 WINDOW CONTRACTOR SHALL FIELD VERIFY ALL VERTICAL AND HORIZONTAL MULLION PLACEMENT WITH SHGC: 0.18 EXISTING WINDOW TO BE REPLACED SO AS TO MATCH EXISTING PATTERN PRIOR TO ORDERING NEW WINDOW UNIT
 VT: 0.42
 FRAME FINISH: EXTERIOR—BLACK/INTERIOR—BLACK
 FIN TYPE: STANDARD Z-BAR
8. WINDOW CONTRACTOR SHALL COORDINATE REMOVAL AND INSTALLATION SCHEDULE WITH CITY HALL REPRESENTATIVE PRIOR TO START OF WORK. CITY HALL AND POLICE ANNEX OPERATIONS SHALL TAKE PRECEDENCE OVER ANY WORK SCHEDULE. THE WINDOW CONTRACTOR SHALL ADJUST THE INSTALLATION SCHEDULE TO ADHERE TO THE CITY HALL AND/OR POLICE DEPARTMENT REQUIREMENTS
9. WINDOW CONTRACTOR SHALL COORDINATE WITH THE CITY HALL REPRESENTATIVE AS TO CERTAIN WINDOW UNITS REQUIRING OPERABLE (CASEMENT) CAPABILITIES
10. ALL WINDOW UNITS BELOW THE FIRST FLOOR SHALL BE FIXED WITH OPAQUE SAFETY GLAZING
11. WINDOW CONTRACTOR SHALL FIELD VERIFY PRIOR TO INSTALLATION ANY WINDOW UNITS REQUIRING SAFETY GLASS TO BE INSTALLED IN PART OR ALL OF THE WINDOW UNIT AS REQUIRED BY CODE
12. WINDOW CONTRACTOR IS REQUIRED TO VERIFY THE TOTAL NUMBER OF ALL WINDOW UNITS BEING RETROFITTED AND THE ACTUAL INSTALLATION SIZE OF EACH UNIT BEING INSTALLED
13. SEE SPECIAL ROOF ACCESS WINDOW/DOOR REQUIREMENTS (SHEET 3) FOR DESIGN CRITERIA. WINDOW OR DOOR UNIT SHALL OPEN 90 DEGREES TO ALLOW ACCESS ON TO THE ROOF AREAS. GLAZING SHALL MEET THE MINIMUM EFFICIENCIES LISTED (SEE NOTE #7)

CITY PARKING LOT

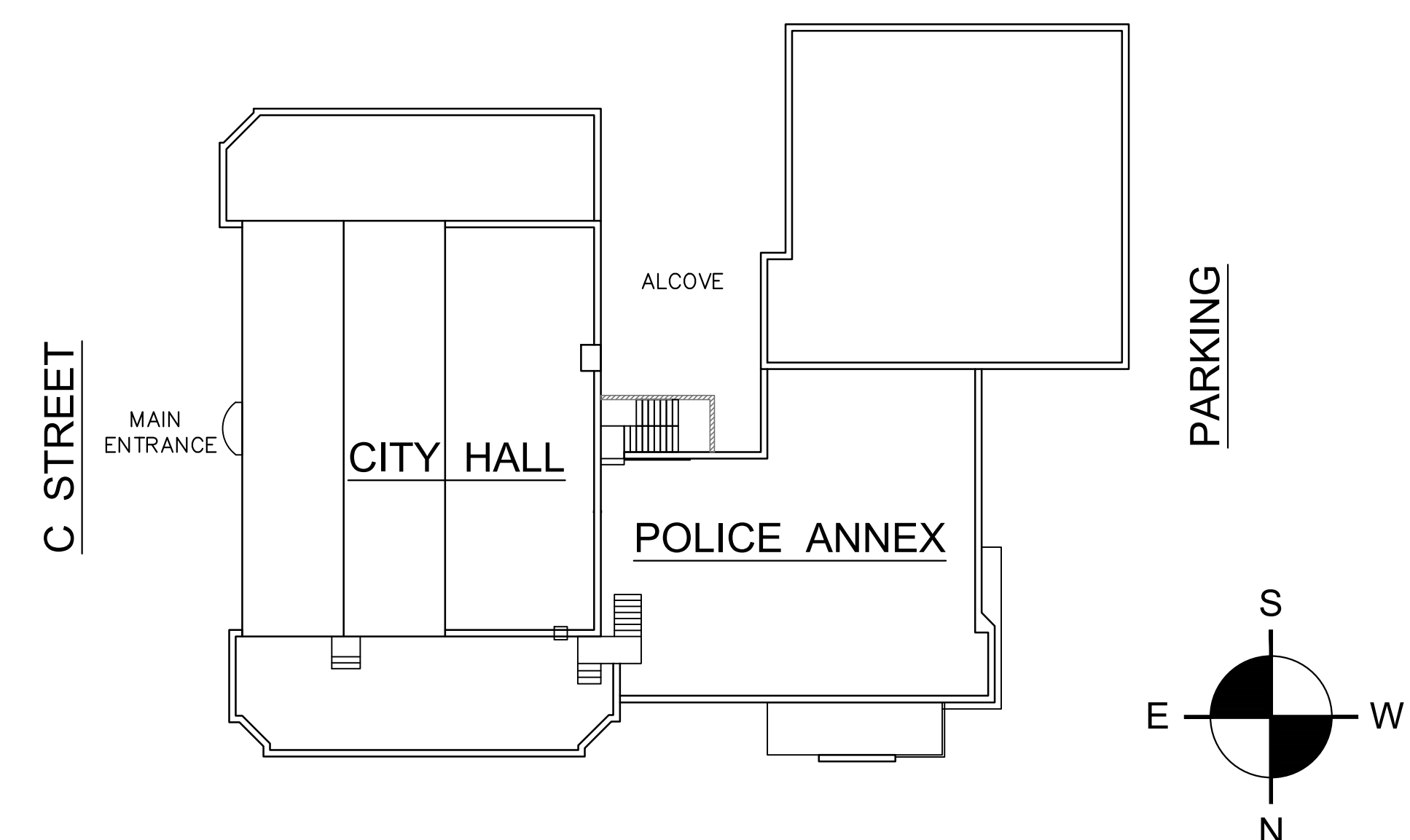

SIXTH STREET

CITY HALL LEGEND

SHEET INDEX	
A1.0	CITY HALL ELEVATIONS, LEGEND AND GENERAL NOTES
A2.0	MILGARD WINDOW DETAILS
A3.0	MIGARD WINDOW DETAILS
A4.0	WINDOW SCHEDULE, SILL CAP AND VERTICAL RAIL DETAIL
A5.0	WINDOW LOCATIONS AT BUILDING ELEVATION
A6.0	WINDOW LOCATIONS AT BUILDING ELEVATION

CITY HALL REPRESENTATIVE CONTACT INFO:
 JERRY HANDY
 4JCON, LLC
 530-682-6129
 jerry@4jcon.com



EAST ELEVATION
MAIN ENTRANCE



NORTH ELEVATION



SOUTH ELEVATION
LOWER LEVEL

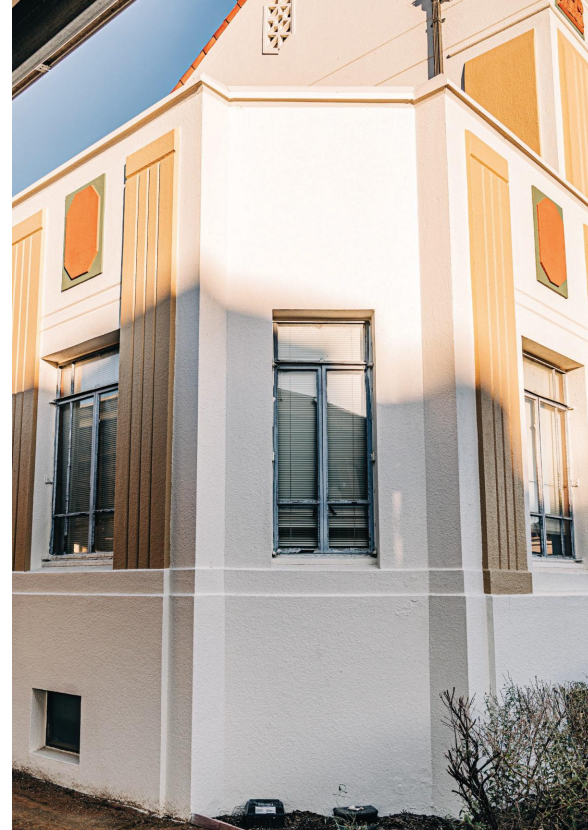

SOUTH-EAST ELEVATION



WEST ALCOVE ELEVATION

CITY HALL - MAIN BUILDING

GENERAL OVERVIEW (WINDOWS SHOWN ARE EXISTING CONDITION)



NORTH ELEVATION-1



NORTH ELEVATION-2



NORTH-WEST ELEVATION



WEST ELEVATION

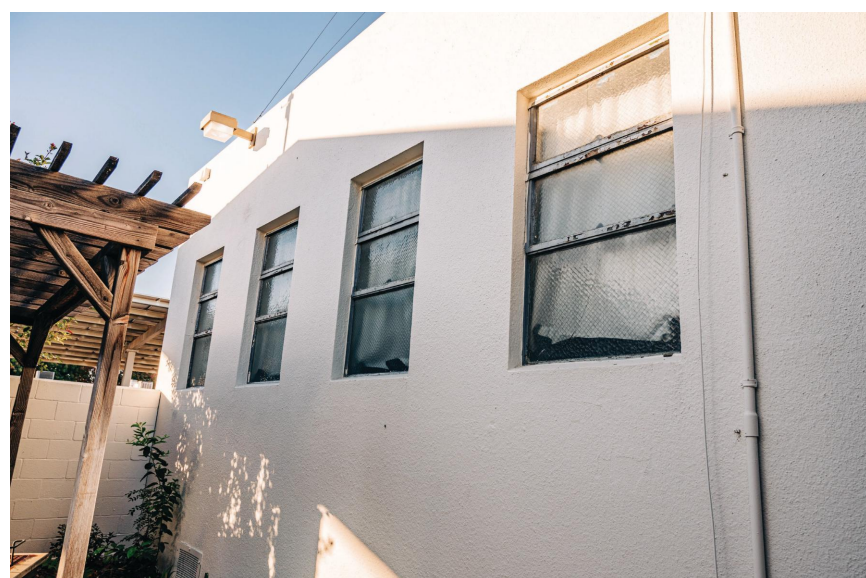

EAST ALCOVE ELEVATION-1

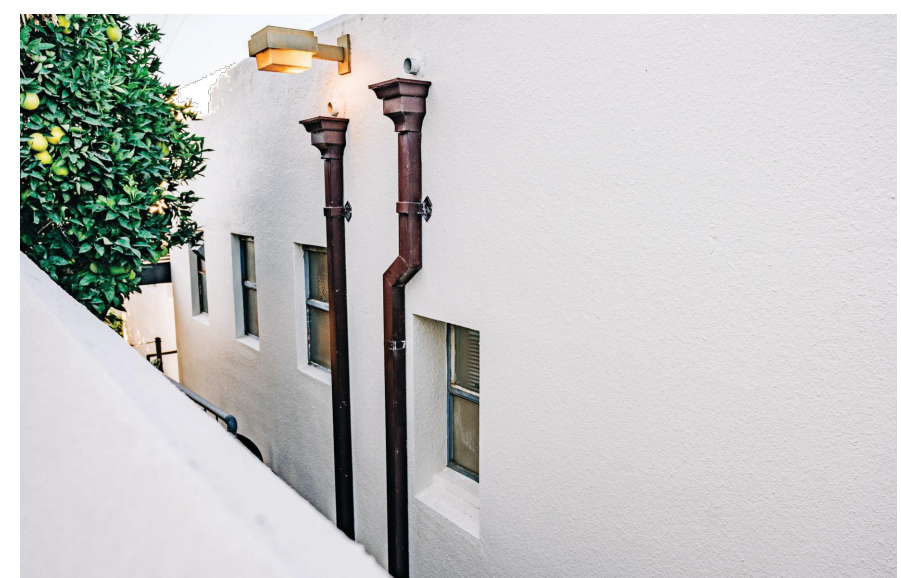

EAST ALCOVE ELEVATION-2

CITY HALL - POLICE ANNEX

GENERAL OVERVIEW (WINDOWS SHOWN ARE EXISTING CONDITION)

Revisions

J.B. SANDGREN ENGINEERING
 120 N. AUBURN STREET, SUITE 200
 GRASS VALLEY, CA 95945
 OFFICE: (530) 742-1331
 EMAIL: JEFF@JBSANDGREN.COM

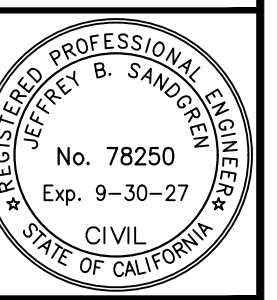

CITY HALL - EXTERIOR WINDOW RETROFIT
 CITY OF MARYSVILLE
 526 C STREET MARYSVILLE, CA 95901

DENNIS C. NELSON COMPANY
 BUILDING DESIGN, LAND USE PLANNING
 AND CONSTRUCTION MANAGEMENT
 120 N. AUBURN STREET, SUITE 200
 GRASS VALLEY, CA 95945
 Bus: (530) 674-7501 Fax: (530) 674-7503
 Email: dcn@denng.com

Date: 4/22/2026
 Scale: NONE
 Drawn: D.NELSON
 Job: 24-3352W
 Sheet:

A1.0

MILGARD
WINDOWS and DOORS

Line No: 9
Location/Label: North Side PD
Quantity: 1
Product Line: V400 Tuscany
Model: Casement/awning (Direct Glass)
Size: 48" Frame, 34" x 30"
Material: Ex: Black / In: Black
Finish: Ex: Black / In: Black
Glass: LWP SunClearMAX Low E1 Tempered over LWP P558 (Standard Obscure) Tempered with Gray Foam Spacer
U-Factor / SHGC / VT: .29 / .57 / .85
Calculations: LWP Area: 93.14, LWP Perimeter: (included in Item 9), SF
Rating: STC: 28, OTC: 23, PSL: LC-P508

Viewed from Exterior (Net Frame)

L

Legend: O = Obscure
T = Tempered
E = Meets Egress per IBC (International Building Code) for above grade application. Validate against local codes.

Quote Number: SQPR0002734_1
Last Modified Date: 10/1/2025 12:40 PM
Page: 9 of 17

MILGARD
WINDOWS and DOORS

Line No: 12
Location/Label: North Side PD
Quantity: 2
Product Line: V400 Tuscany
Model: Casement/awning (Direct Glass)
Size: 48" Frame, 36" x 42"
Material: Ex: Black / In: Black
Finish: Ex: Black / In: Black
Glass: LWP SunClearMAX Low E1 over LWP P558 (Standard Obscure) with Gray Foam Spacer
U-Factor / SHGC / VT: .29 / .57 / .85
Calculations: LWP Area: 93.14, LWP Perimeter: (included in Item 12), SF
Rating: STC: 28, OTC: 23, PSL: LC-P508

Viewed from Exterior (Net Frame)

O

Legend: O = Obscure
T = Tempered
E = Meets Egress per IBC (International Building Code) for above grade application. Validate against local codes.

Quote Number: SQPR0002734_1
Last Modified Date: 10/1/2025 12:40 PM
Page: 12 of 17

MILGARD
WINDOWS and DOORS

Line No: 18
Location/Label: Awning/Roof
Quantity: 6
Product Line: V400 Tuscany
Model: Special Composite Design
Size: 48" Frame, 34" x 30"
Dimensions: CANS 1, 30" x 41", CANS 2, 34" x 30"
Material: Ex: Black / In: Black
Finish: Ex: Black / In: Black
Glass: LWP SunClearMAX Low E1 over LWP P558 (Standard Obscure) with Gray Foam Spacer
U-Factor / SHGC / VT: .29 / .57 / .85
Calculations: LWP Area: 93.14, LWP Perimeter: (included in Item 18), SF
Rating: STC: 28, OTC: 23, PSL: LC-P508

Viewed from Exterior (Net Frame)

R

Legend: O = Obscure
T = Tempered
E = Meets Egress per IBC (International Building Code) for above grade application. Validate against local codes.

Quote Number: SQPR0002734_1
Last Modified Date: 10/1/2025 12:40 PM
Page: 14 of 17

MILGARD
WINDOWS and DOORS

Line No: 10
Location/Label: North Side PD
Quantity: 1
Product Line: V400 Tuscany
Model: Casement/awning (Direct Glass)
Size: 48" Frame, 34" x 30"
Material: Ex: Black / In: Black
Finish: Ex: Black / In: Black
Glass: LWP SunClearMAX Low E1 over LWP P558 (Standard Obscure) with Gray Foam Spacer
U-Factor / SHGC / VT: .29 / .57 / .85
Calculations: LWP Area: 93.14, LWP Perimeter: (included in Item 10), SF
Rating: STC: 28, OTC: 23, PSL: LC-P508

Viewed from Exterior (Net Frame)

M

Legend: O = Obscure
T = Tempered
E = Meets Egress per IBC (International Building Code) for above grade application. Validate against local codes.

Quote Number: SQPR0002734_1
Last Modified Date: 10/1/2025 12:40 PM
Page: 10 of 17

MILGARD
WINDOWS and DOORS

Line No: 11
Location/Label: Awning/Roof
Quantity: 4
Product Line: V400 Tuscany
Model: Casement/awning (Direct Glass)
Size: 48" Frame, 36" x 42"
Material: Ex: Black / In: Black
Finish: Ex: Black / In: Black
Glass: LWP SunClearMAX Low E1 over LWP P558 (Standard Obscure) with Gray Foam Spacer
U-Factor / SHGC / VT: .29 / .57 / .85
Calculations: LWP Area: 93.14, LWP Perimeter: (included in Item 11), SF
Rating: STC: 28, OTC: 23, PSL: LC-P508

Viewed from Exterior (Net Frame)

P

Legend: O = Obscure
T = Tempered
E = Meets Egress per IBC (International Building Code) for above grade application. Validate against local codes.

Quote Number: SQPR0002734_1
Last Modified Date: 10/1/2025 12:40 PM
Page: 17 of 17

MILGARD
WINDOWS and DOORS

Line No: 15
Location/Label: Awning/Roof
Quantity: 7
Product Line: V400 Tuscany
Model: Special Composite Design
Size: 48" Frame, 34" x 30"
Dimensions: CANS 1, 30" x 41", CANS 2, 34" x 30"
Material: Ex: Black / In: Black
Finish: Ex: Black / In: Black
Glass: LWP SunClearMAX Low E1 Tempered over LWP P558 (Standard Obscure) with Gray Foam Spacer
U-Factor / SHGC / VT: .29 / .57 / .85
Calculations: LWP Area: 93.14, LWP Perimeter: (included in Item 15), SF
Rating: STC: 28, OTC: 23, PSL: LC-P508

Viewed from Exterior (Net Frame)

S

Legend: O = Obscure
T = Tempered
E = Meets Egress per IBC (International Building Code) for above grade application. Validate against local codes.

Quote Number: SQPR0002734_1
Last Modified Date: 10/1/2025 12:40 PM
Page: 15 of 17

MILGARD
WINDOWS and DOORS

Line No: 13
Location/Label: North Side PD
Quantity: 1
Product Line: V400 Tuscany
Model: Casement/awning (Direct Glass)
Size: 48" Frame, 34" x 30"
Material: Ex: Black / In: Black
Finish: Ex: Black / In: Black
Glass: LWP SunClearMAX Low E1 Tempered over LWP P558 (Standard Obscure) with Gray Foam Spacer
U-Factor / SHGC / VT: .29 / .57 / .85
Calculations: LWP Area: 93.14, LWP Perimeter: (included in Item 13), SF
Rating: STC: 28, OTC: 23, PSL: LC-P508

Viewed from Exterior (Net Frame)

N

Legend: O = Obscure
T = Tempered
E = Meets Egress per IBC (International Building Code) for above grade application. Validate against local codes.

Quote Number: SQPR0002734_1
Last Modified Date: 10/1/2025 12:40 PM
Page: 11 of 17

MILGARD
WINDOWS and DOORS

Line No: 16
Location/Label: Awning/Roof
Quantity: 4
Product Line: V400 Tuscany
Model: Casement/awning (Direct Glass)
Size: 48" Frame, 36" x 42"
Material: Ex: Black / In: Black
Finish: Ex: Black / In: Black
Glass: LWP SunClearMAX Low E1 over LWP P558 (Standard Obscure) with Gray Foam Spacer
U-Factor / SHGC / VT: .29 / .57 / .85
Calculations: LWP Area: 93.14, LWP Perimeter: (included in Item 16), SF
Rating: STC: 28, OTC: 23, PSL: LC-P508

Viewed from Exterior (Net Frame)

Q

Legend: O = Obscure
T = Tempered
E = Meets Egress per IBC (International Building Code) for above grade application. Validate against local codes.

Quote Number: SQPR0002734_1
Last Modified Date: 10/1/2025 12:40 PM
Page: 16 of 17

Revisions

J.B. SANDGREN ENGINEERING
120 N. AUBURN STREET, SUITE 200
GRASS VALLEY, CALIFORNIA 95945
OFFICE (530) 788-8794 • FAX (530) 742-1331
EMAIL: JEFF@JBSANDGREN.COM



CITY HALL – EXTERIOR WINDOW RETROFIT
CITY OF MARYSVILLE
526 C STREET MARYSVILLE, CA 95901

DENNIS C. NELSON COMPANY
BUILDING DESIGN, LAND USE PLANNING
AND CONSTRUCTION MANAGEMENT
120 N. AUBURN STREET, SUITE 200
GRASS VALLEY, CA 95945
Phone: (530) 674-7500 | Fax: (530) 674-7503
Email: dcnelson@syk.com

Date: 4/22/2026
Scale: NONE
Drawn: D.NELSON
Job: 24-3352W
Sheet

A3.0

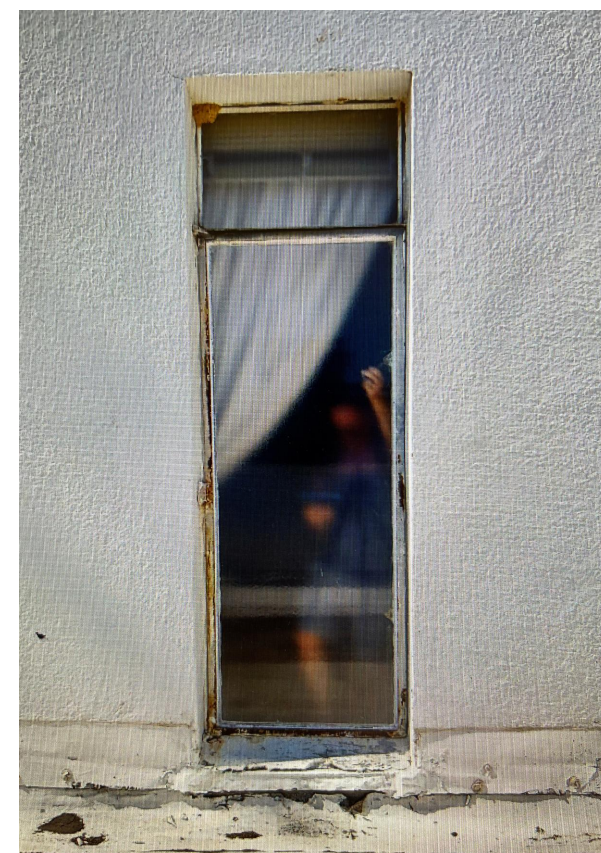

SOUTH UNIT
(NORTH UNIT SIMILAR)

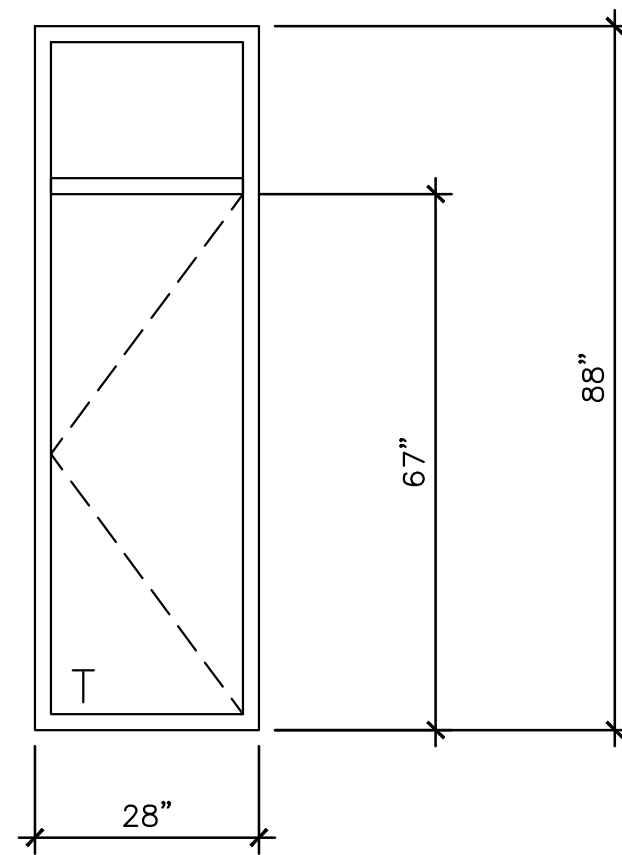

- SPECIAL UNIT #1 NORTH ACCESS AT END OF 2ND FLOOR HALLWAY (QUANTITY 1)
- SPECIAL UNIT #2 SOUTH ACCESS AT 2ND FLOOR CONFERENCE ROOM (QUANTITY 1)
- CASEMENT UNIT WITH FULL 90 DEGREE SWING
- OPTIONAL FULL GLASS DOOR & TRANSOM W/ HOLLOW METAL FRAME TO FIT EXISTING OPENING (COLOR BLACK)
- NOTE: PROVIDE SHOP DRAWING FOR DESIGN APPROVAL

City of Marysville City Hall
Line 1

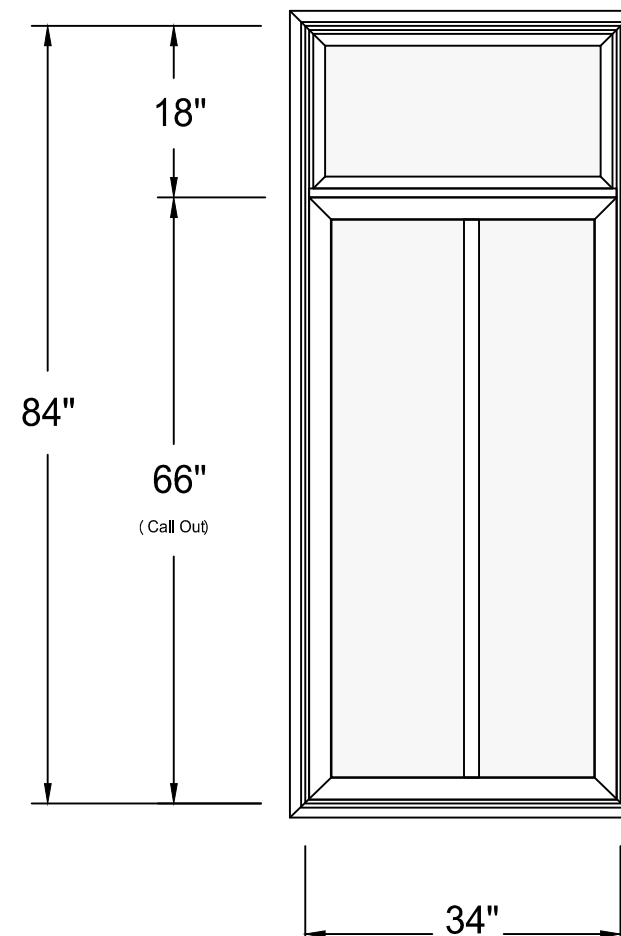

Viewed from Exterior (Net Frame)

NOTE: CENTER AND HORIZONTAL MULLIONS ADDED TO REPLICATE THE APPEARANCE OF A PAIR OF CASEMENTS TO THE ACTUAL FIXED WINDOW UNIT

City of Marysville City Hall
Lines 4, 7, & 13

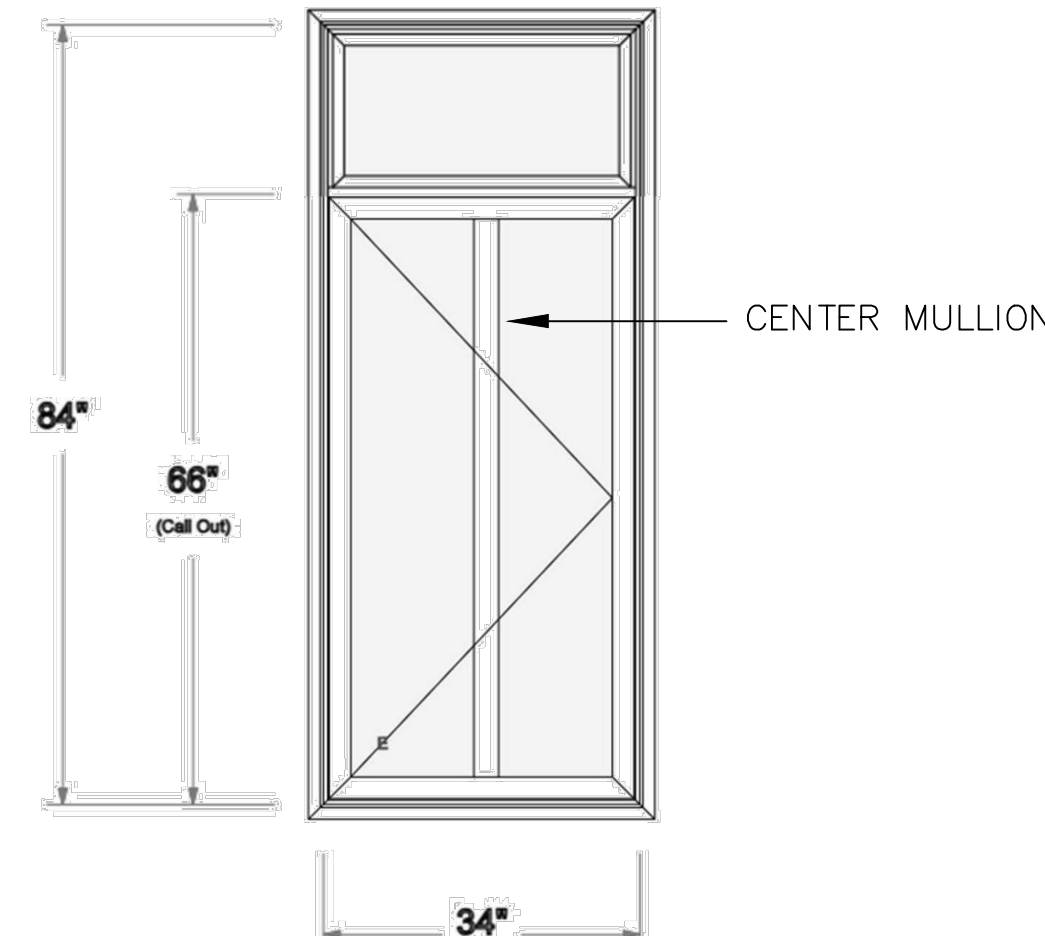

Viewed from Exterior (Net Frame)

NOTE: CENTER MULLION ADDED TO REPLICATE THE APPEARANCE OF A PAIR OF CASEMENTS TO THE ACTUAL SINGLE CASEMENT WINDOW UNIT

City of Marysville City Hall
Lines 10 & 11

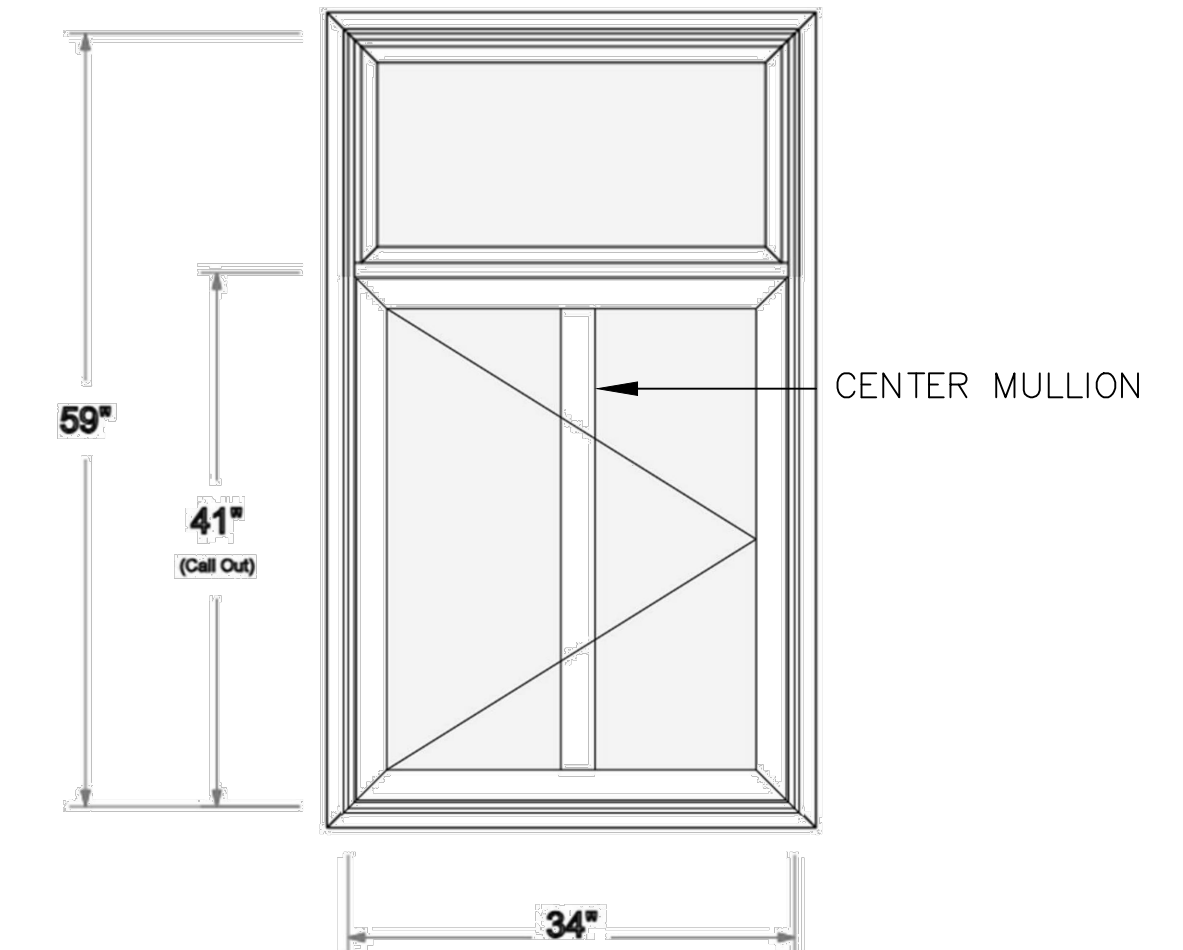

Viewed from Exterior (Net Frame)

NOTE: CENTER MULLION ADDED TO REPLICATE THE APPEARANCE OF A PAIR OF CASEMENTS TO THE ACTUAL SINGLE CASEMENT WINDOW UNIT

SPECIAL ROOF ACCESS WINDOW / DOOR

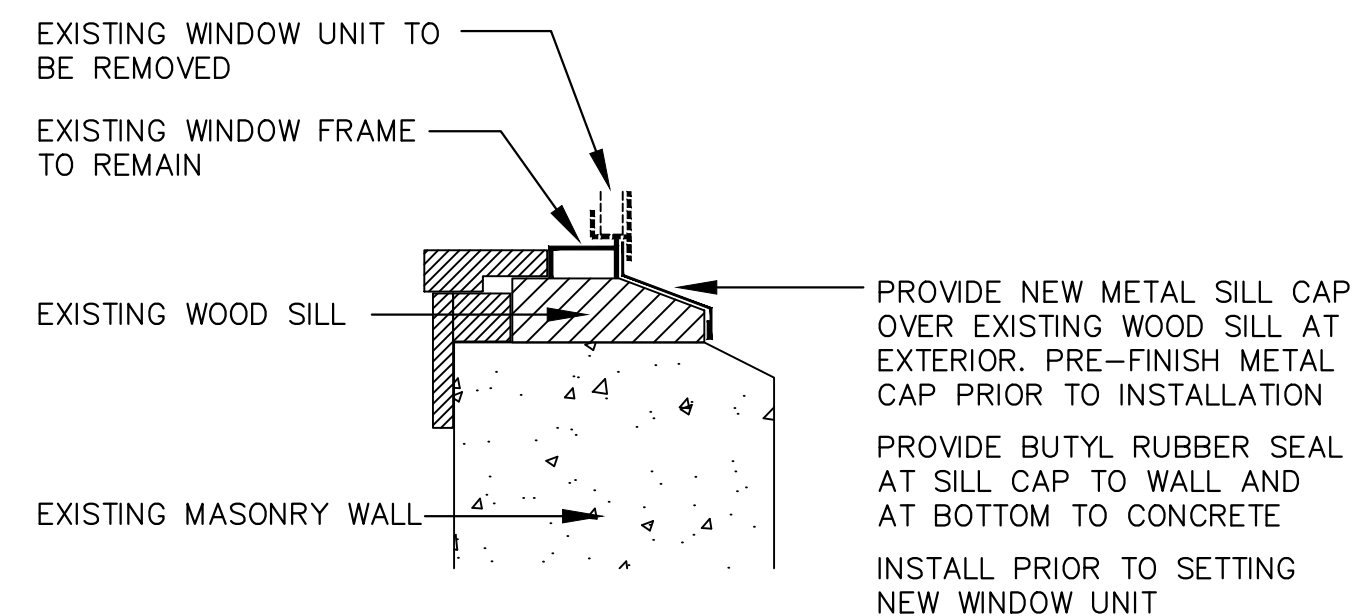

TYPICAL METAL WINDOW SILL CAP
SCALE: NONE

SPECIAL RAIL DIAGRAMS - MULLION PLACEMENTS

WINDOW SCHEDULE						
Type Mark	Family and Type	Count	Location	Size	Glazing Type O / T / E	Remarks
A	Milgard V400 Tuscan	10	East Side City Hall	Net Frame: 34" x 84"		Checkrail per Diagram
B	Milgard V400 Tuscan	7	5 East Side City Hall 2 City Hall North Roof	Net Frame: 70" x 106"		
C	Milgard V400 Tuscan	2	East Side City Hall	Net Frame: 57" x 84"		
D	Milgard V400 Tuscan	7	6 North Side City Hall 1 North West Corner City Hall by PD	Net Frame: 34" x 84"	E	Checkrail per Diagram
E	Milgard V400 Tuscan	2	North Side City Hall	Net Frame: 57" x 84"		
F	Milgard V400 Tuscan	1	South Side City Hall	Net Frame: 57" x 84"		
G	Milgard V400 Tuscan	5	4 South Side City Hall 1 South East Corner City Hall	Net Frame: 34" x 84"	E	Checkrail per Diagram
H	Milgard V400 Tuscan	6	West Side City Hall Alcove	Net Frame: 34" x 84"	E	Checkrail per Diagram
I	Not Used					
J	Not Used					
K	Milgard V400 Tuscan	22	7 East Side City Hall Ground Level 5 North Side City Hall Ground Level 5 South Side City Hall Ground Level 5 West Side City Hall Alcove Ground Level	Net Frame: 32" x 23"	T / O	
L	Milgard V400 Tuscan	1	North Side PD by City Hall	Net Frame: 28" x 50"	T / O	
M	Milgard V400 Tuscan	3	North Side PD	Net Frame: 34" x 59"		Checkrail per Diagram
N	Milgard V400 Tuscan	2	North Side PD Each Side of Entrance	Net Frame: 34" x 59"	T	Checkrail per Diagram. Top and Bottom Window tempered
O	Milgard V400 Tuscan	2	1 North Side PD Corner 1 West Side PD Corner	Net Frame: 60" x 47"		
P	Milgard V400 Tuscan	4	East Side PD Alcove	Net Frame: 22" x 35"	O	
Q	Milgard V400 Tuscan	5	East Side PD Alcove	Net Frame: 33" x 60"	O	
R	Milgard V400 Tuscan	7	6 West Side City Hall Roof 1 East Side PD by Bike Rack	Net Frame: 34" x 59"		
S	Milgard V400 Tuscan	2	1 West Side City Hall Roof 1 South Side City Hall Roof	Net Frame: 34" x 59"	T	Top and Bottom Window tempered

O = Obscured
T = Tempered
E = Meets Egress per IBC (International Building Code) for above grade application. Validate against local codes.

Revisions

J.B. SANDGREN ENGINEERING
120 N. AUBURN STREET, SUITE 200
GRASS VALLEY, CALIFORNIA 95945
OFFICE (530) 788-8794 • FAX (530) 742-1331
EMAIL: JEFF@JBSANDGREN.COM

REGISTERED PROFESSIONAL ENGINEER
No. 78250
Exp. 9-30-27
CIVIL
STATE OF CALIFORNIA

CITY HALL - EXTERIOR WINDOW RETROFIT
CITY OF MARYSVILLE
526 C STREET MARYSVILLE, CA 95901

DENNIS C. NELSON COMPANY
BUILDING DESIGN, LAND USE PLANNING
AND CONSTRUCTION MANAGEMENT
120 N. AUBURN STREET, SUITE 200
GRASS VALLEY, CALIFORNIA 95945
PHONE (530) 742-1301 • FAX (530) 674-7503
Email: dchen@dncc.com

Date: 4/22/2026
Scale: NONE
Drawn: D.NELSON
Job: 24-3352W
Sheet:

A4.0

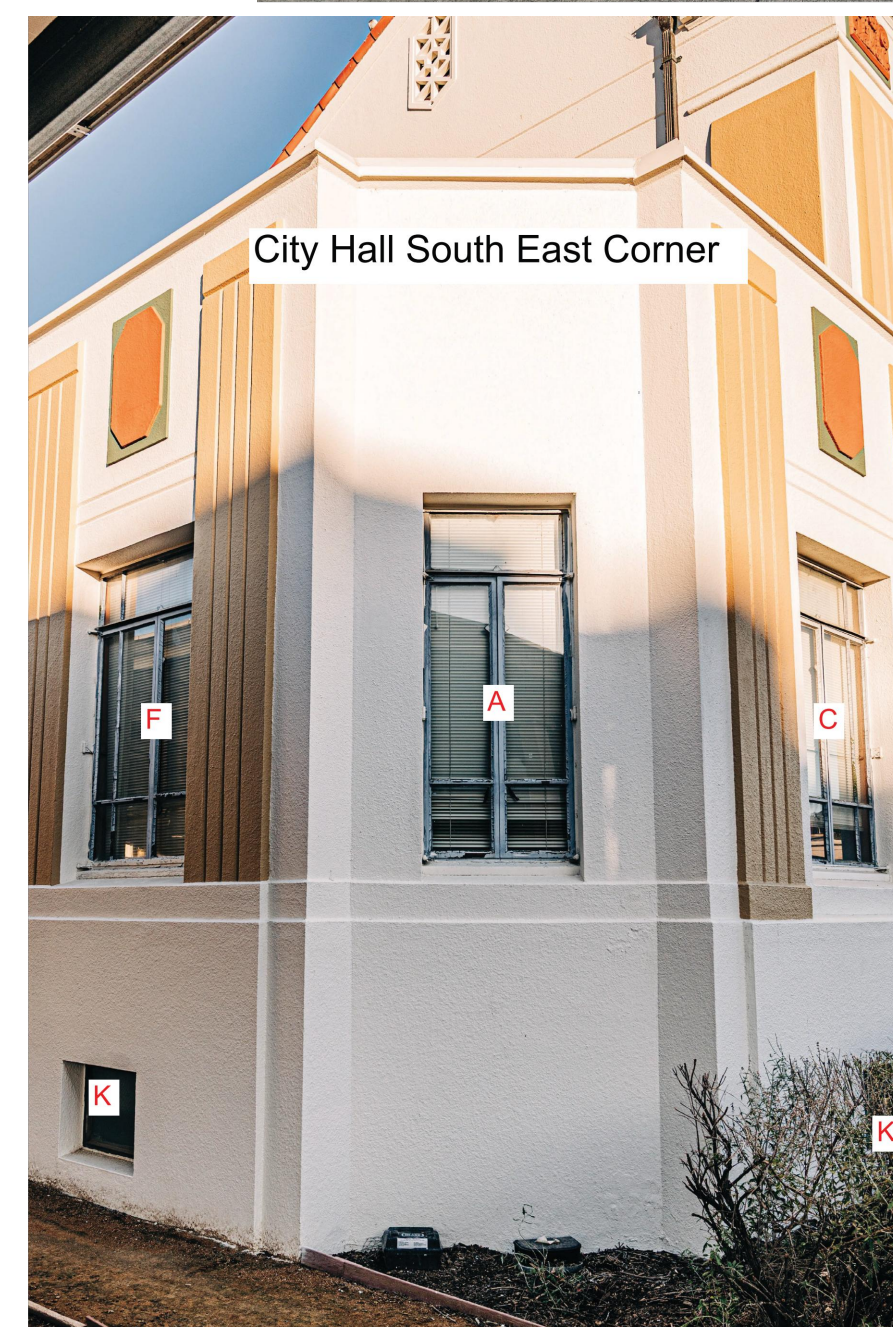

Revisions

J.B. SANDGREN ENGINEERING
 120 N. AUBURN STREET, SUITE 200
 GRASS VALLEY, CALIFORNIA 95945
 OFFICE (530) 788-8794 • FAX (530) 742-1331
 EMAIL: JEFF@JBSANDGREN.COM



CITY HALL – EXTERIOR WINDOW RETROFIT
CITY OF MARYSVILLE
 526 C STREET MARYSVILLE, CA 95901

DENNIS C. NELSON COMPANY
 BUILDING DESIGN, LAND USE PLANNING
 AND CONSTRUCTION MANAGEMENT
 120 N. AUBURN STREET, SUITE 200
 GRASS VALLEY, CA 95945
 Email: dcnelson@dcn.com

Date 4/22/2026
 Scale NONE
 Drawn D.NELSON
 Job 24-3352W
 Sheet

A5.0

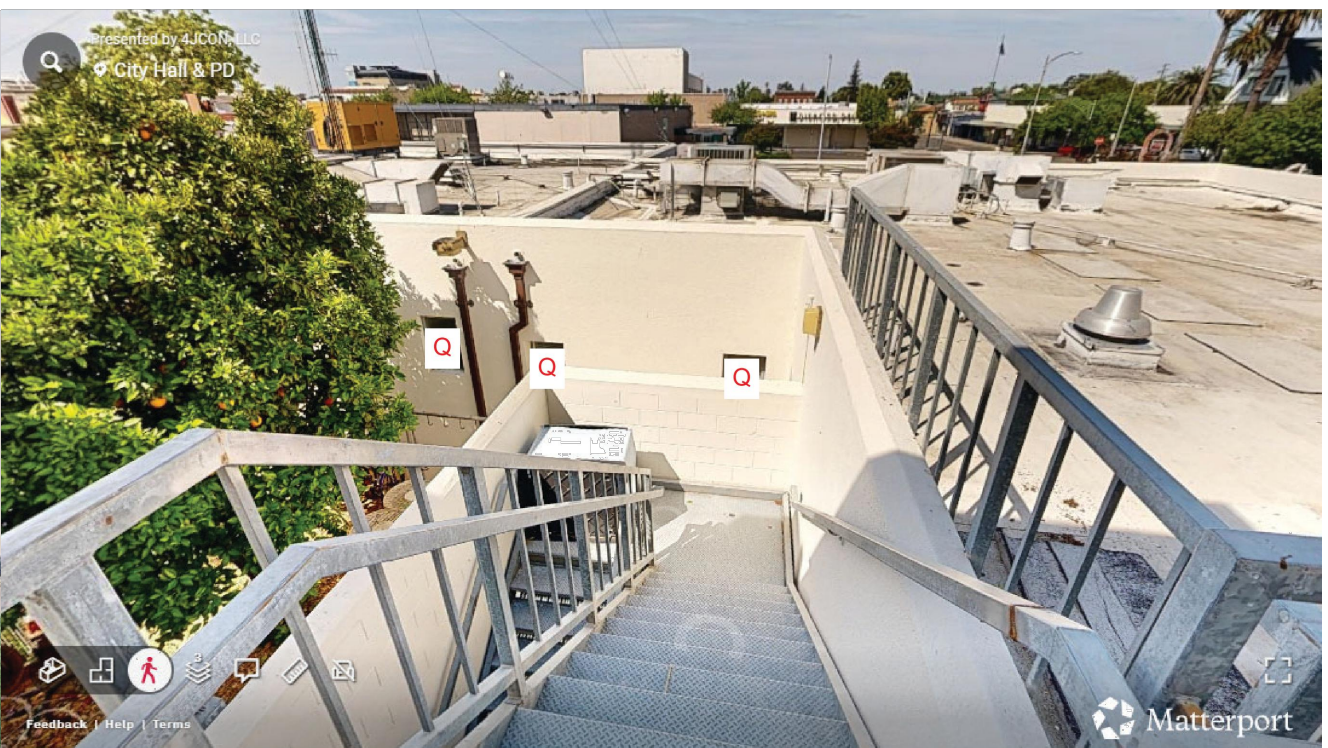
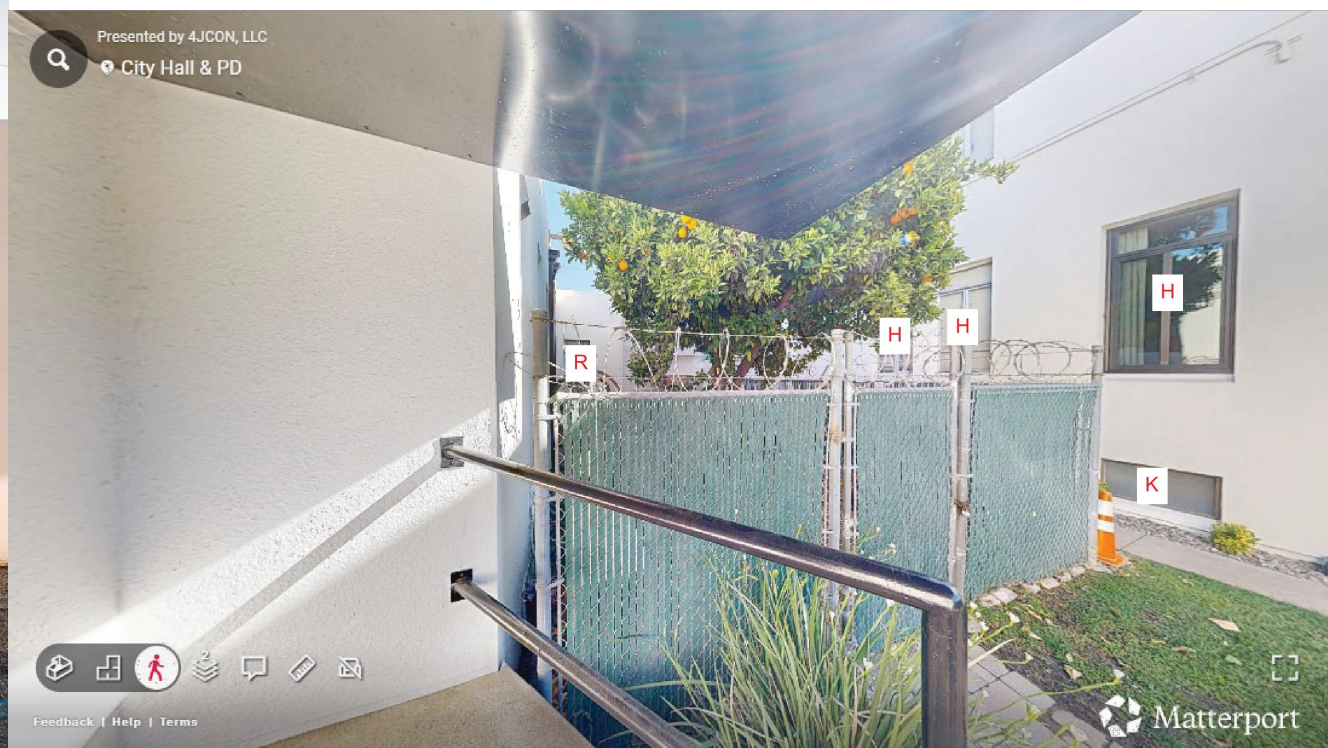
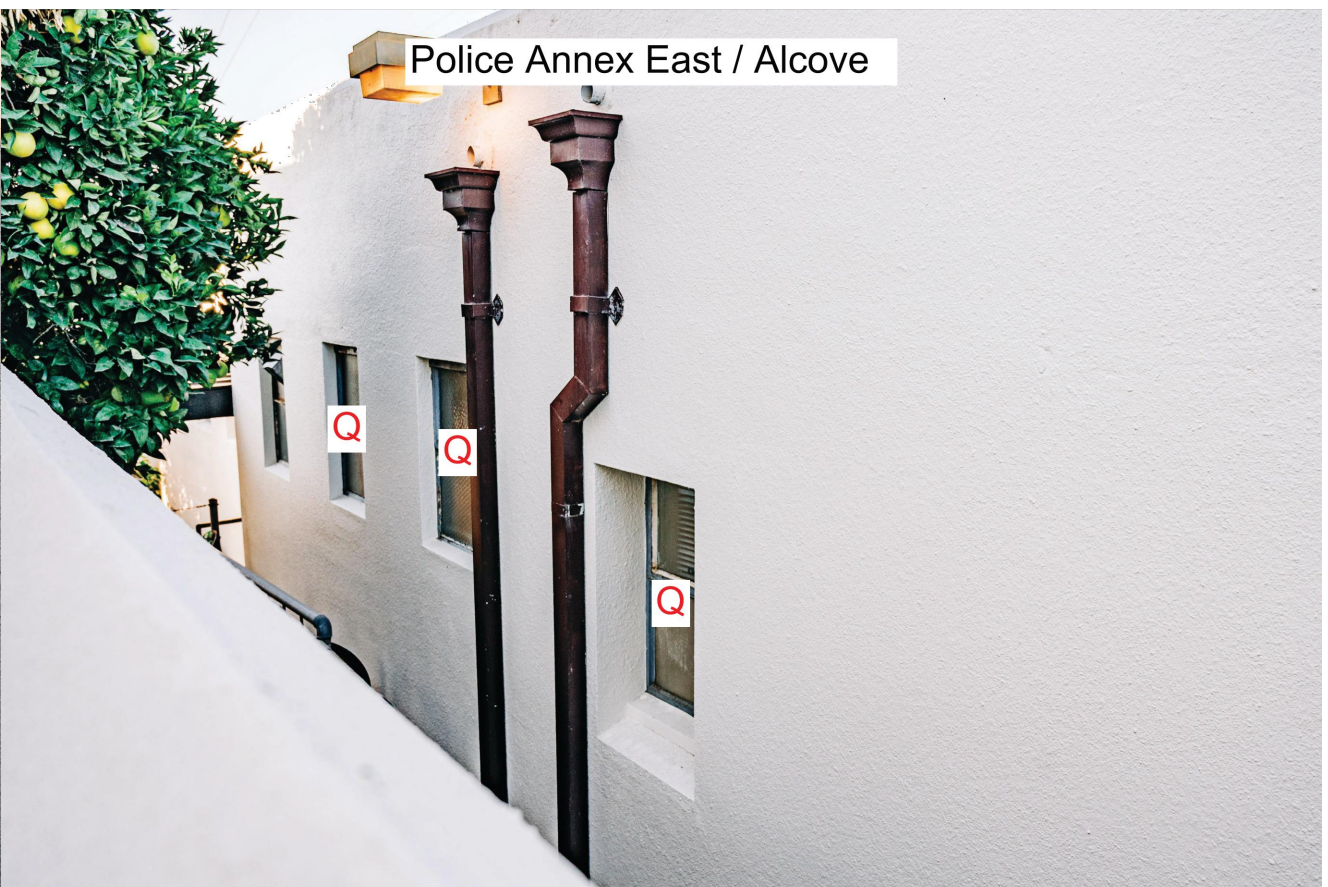
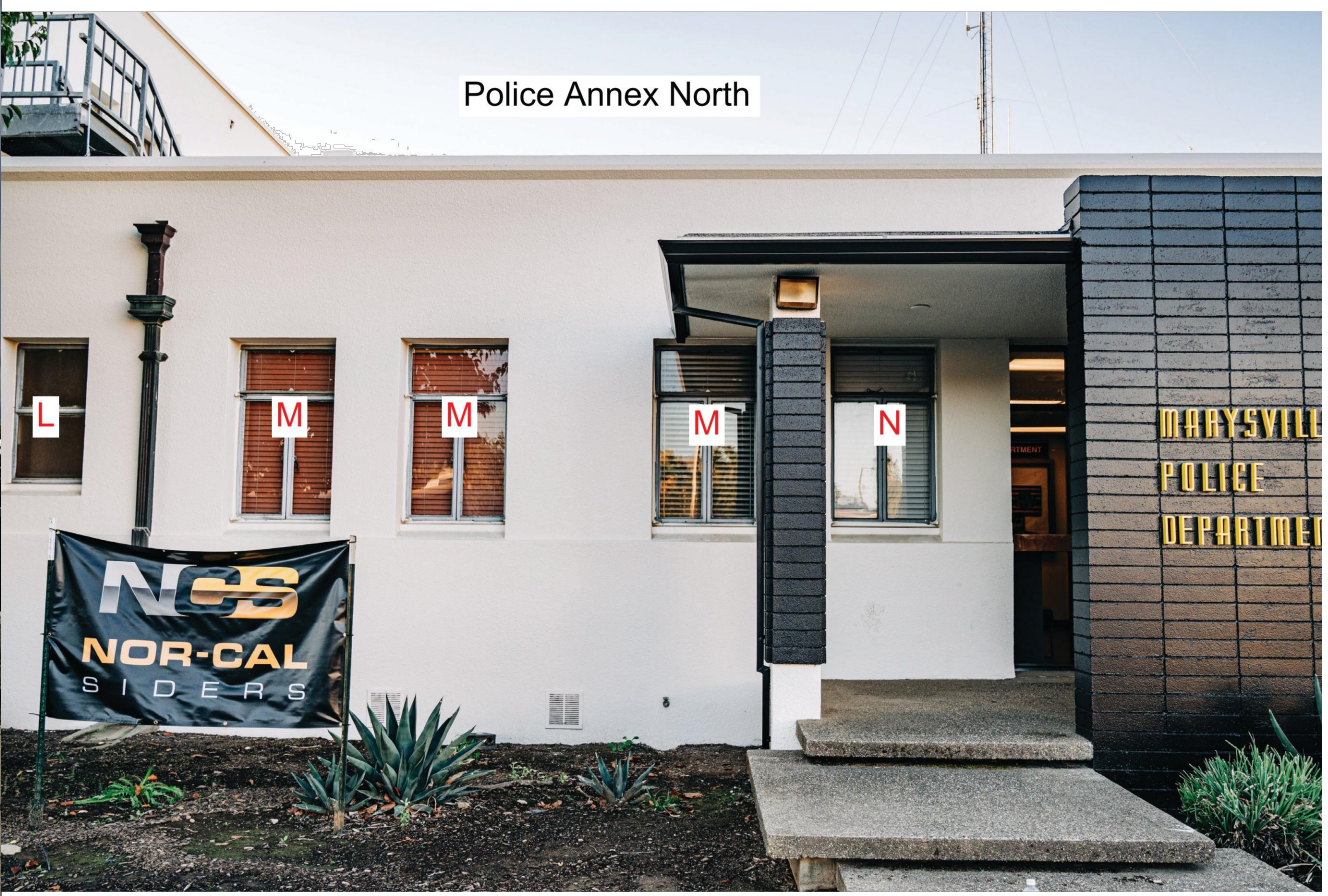
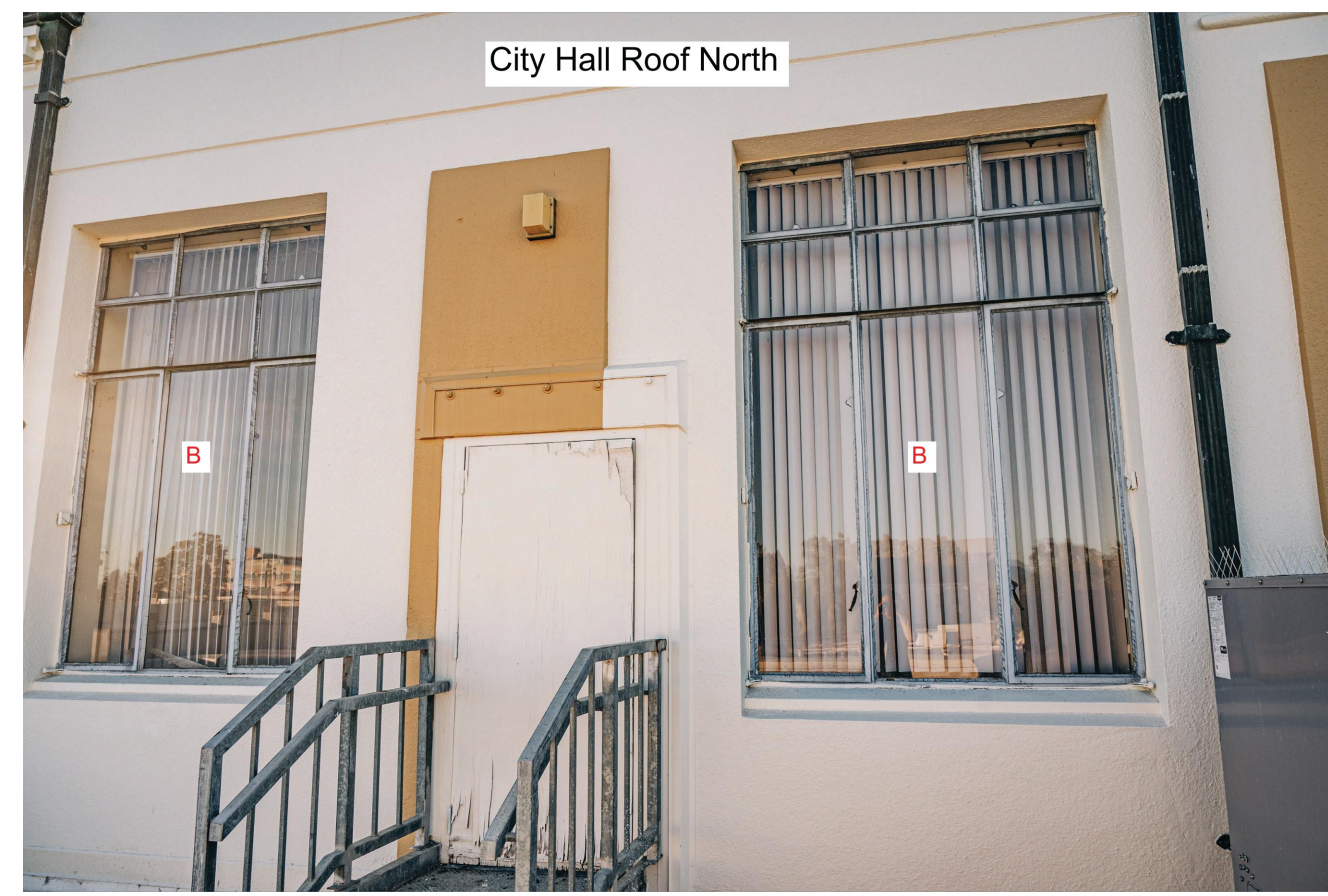

Revisions	

J.B. SANDGREN ENGINEERING
 120 N. AUBURN STREET, SUITE 200
 GRASS VALLEY, CALIFORNIA 95945
 OFFICE (530) 788-8794 • FAX (530) 742-1331
 EMAIL: JEFF@JBSANDGREN.COM



CITY HALL – EXTERIOR WINDOW RETROFIT
CITY OF MARYSVILLE
 526 C STREET MARYSVILLE, CA 95901

DENNIS C. NELSON COMPANY
 BUILDING DESIGN, LAND USE PLANNING
 AND CONSTRUCTION MANAGEMENT
 120 N. AUBURN STREET, SUITE 200
 GRASS VALLEY, CA 95945
 Email: dcnelson@pcyx.com

Date: 4/22/2026
 Scale: NONE
 Drawn: D.NELSON
 Job: 24-3352W
 Sheet:

A6.0