

NOTE:

1. MIN. D/W SLAB THICKNESS IN SINGLE FAMILY RESIDENTIAL AREAS SHALL BE 4".
2. MIN. LENGTH OF RESIDENTIAL D/W SHALL BE 12' & MAX. LENGTH 24'.
3. ALL CONCRETE REMOVALS SHALL BE TO NEAT SAW CUT LINES.
4. 90% RELATIVE COMPACTION REQUIRED ON SUBGRADE.
5. DRIVEWAY APPROACH SHALL BE POURED SEPARATELY WITH CURB UNLESS OTHERWISE APPROVED BY THE ENGINEER.
6. ON SITE GRADING MAY BE REQUIRED TO ELIMINATE EXCESSIVE GRADE CHANGE AND TO MAINTAIN SUITABLE DRAINAGE.
7. MAXIMUM CURB OPENING MAY BE INCREASED DUE TO SPECIAL CONDITIONS ON APPROVAL OF THE CITY ENGINEER.

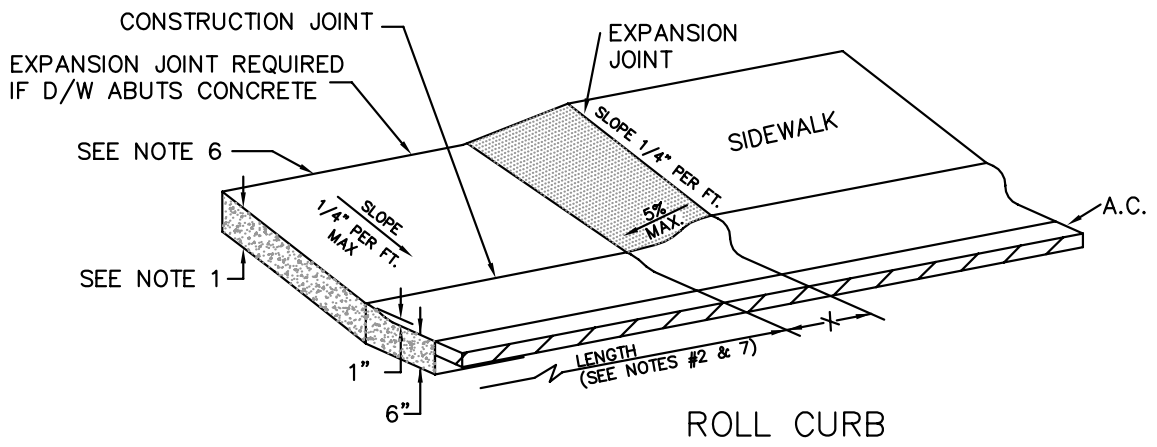

DEPARTMENT OF CITY SERVICES

STANDARD DETAIL 104

APPROVED

DATE

**Standard
Driveway**